



VOL. 2, NO. 3, JULY - SEPTEMBER 1975

SERVICE NEWS

A SERVICE PUBLICATION OF LOCKHEED-GEORGIA COMPANY, A DIVISION OF LOCKHEED AIRCRAFT CORPORATION



SERVICE NEWS

A SERVICE PUBLICATION OF
LOCKHEED-GEORGIA COMPANY
A DIVISION OF
LOCKHEED AIRCRAFT CORPORATION

Editor

Jay V. Roy

Associate Editors

James W. Buttram

James A. Loftin

Art Direction & Production

Anne G. Anderson

SERVICE NEWS



COVER: New Hercules for Philippine Aerotransport. This commercial airfreighter will be utilized by the Philippine Government for domestic and international cargo flights.

Published by Lockheed-Georgia Company, a Division of Lockheed Aircraft Corporation. Information contained in this issue is considered by Lockheed-Georgia Company to be accurate and authoritative. It should not be assumed, however, that this material has received approval from any governmental agency or military service unless it is specifically noted. This publication is for planning and information purposes only and it is not to be construed as authority for making changes on aircraft or equipment or as superseding any established operational or maintenance procedures or policies. The following marks are registered and owned by Lockheed Aircraft Corporation: "Service News", "Lockheed", "Hercules", and "JetStar". Written permission must be obtained from Lockheed-Georgia Company before republishing any material in this periodical. Address all communications to Editor, Service News, Department 64-22 Zone 278. Lockheed-Georgia Company, Marietta Georgia 30063. Copyright 1975 Lockheed Aircraft Corporation.

Vol. 2, No. 3, July-September 1975

CONTENTS

- 3 Nuts, Bolts, Screws
- 7 Bolt Identification Chart
- 8 Screw Identification Chart
- 9 Nut Identification Chart
- 12 New Hydraulic Pump Limits Temperature
- 14 Where Did The Oil Go?

DIRECTOR

T. J. CLELAND

MANAGER

D. L. BRAUND

FIELD SERVICE & INVENTORY MGMT

A. H. McCRUM

CUSTOMER TRAINING

A. R. LOVE

JETSTAR SUPPORT

H. L. BURNETTE

SPARES STORES & SHIPPING

J. K. PIERCE

MANAGER

M. M. HODNETT, JR.

SUPPLY PROCUREMENT

R. C. WEIHE

SUPPLY SYSTEM & INVENTORY CONTROL

C. K. ALLEN

SUPPLY SALES & CONTRACTS

H. T. NISSLEY

SUPPLY TECHNICAL SUPPORT

J. L. THURMOND



NUTS BOLTS SCREWS

Many accidents and incidents attributable to maintenance and service errors involve common, simple hardware such as nuts, bolts, and screws. Wrong length, wrong type, and improper installation are the usual troubles.

Before we get into the details, let's review some general rules of the game. Remember, designations used are:

- AN Air Force - Navy Aeronautical Standard
- NAS National Aircraft Standard
- MS Military Standard
- Other Specific Manufacturer's Designation

RULE NO. 1

THE DESCRIPTION OF A BOLT OR SCREW IS GIVEN IN THE BASIC PART NUMBER. The basic part number is the "AN3", the "NAS517", or the "MS20004." We have listed only the most common screws, nuts, and bolts used on the C-130 Hercules and the JetStar. Always take note of whether a bolt or screw is for structural or non-structural application.

RULE NO. 2

THE GRIP LENGTH OF BOLTS AND SCREWS IS USUALLY INDICATED BY THE LAST NUMBER IN THE PART NUMBER. This can be the most confusing part of the callout. The illustration shows how to measure grip length, "useful" length, and overall length. Overall length is usually the most important measurement.

A grip length too short for the material being fastened can cause bolt threads to be in bearing

OR

a grip length too long for the material being fastened can cause the bolt shank to bottom out in the nut without achieving proper clamp-up. Either condition can be critical to the strength and service life of the installation.

The best approach to determining bolt and screw lengths is to use the appropriate chart. A few examples will illustrate:

The AN3-7 is a bolt of 3/16 inch diameter with a grip length of 1/2 inch.

The AN4-7 is a bolt of 1/4 inch diameter with a grip length of 7/16 inch.

The grip length increases 1/8 inch for each increase in dash number; however, there are no dash 8 and 9. Notice that the same dash number denotes a different length for

each diameter change. So, there is no hard and fast rule we can give you concerning bolt grip lengths. You must consult tables.

One more word about the AN bolt series. If you consider the "useful" length - that is, the length as measured from the under side of the head to the last complete thread (usually one thread before the chamfer starts), the dash number will show the useful length in 1/8 inch increments. With double digit dash numbers, such as AN3-27, the 2 stands for 2 inches, the 7 for 7/8 inch; or 2-7/8 inch useful length.

Leaving the AN series of bolts, we find a little more order. For most NAS and MS series bolts, the grip length is given in 1/16 inch increments and the dash number denotes this.

NAS583-7 has a grip length of 7/16 inch.

MS20004-16 has a grip length of 16/16 or 1-inch.

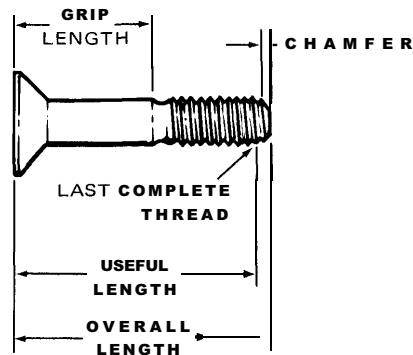
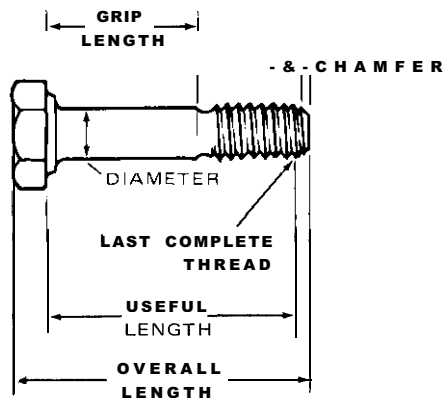

SCREWS

When we talk about screws, it is necessary to differentiate between structural and non-structural screws. Further,

some screws have threads their full length, others have a grip length.

Non-structural screw lengths are generally indicated by their last dash number in 1/16 inch increments. Structural screws used on the Hercules and the JetStar have their grip length given by their last dash number in 1/16 inch increments. For example:

- NAS 5 17-3-4 has a grip length of 1/4 (4/16) inch.
- NAS 517-3-12 has a grip length of 3/4 (12/16) inch.
- NAS 623-3-48 has a grip length of 3 (48/16) inches.

The MS series of screws are different from all the rest. The dash number denotes diameter and length. For example:

MS35214-1, denotes a Pan Head Machine Screw, size No. 2 by 1/8 inch overall length. MS35214-9 denotes a Pan Head Machine Screw, size No. 2 by 3/4 inch overall length. At dash 10 (-10) the diameter jumps to a No. 4, the length reverts back to 1/8 The only way to deal with MS screws is with a chart.

RULE NO. 3

THE DIAMETER OF A BOLT OR SCREW IS INDICATED IN THE PART NUMBER EITHER AS A PORTION OF THE BASIC PART NUMBER OR AS THE FIRST DASH NUMBER IMMEDIATELY FOLLOWING THE BASIC NUMBER, For example:

- AN7-10 bolt is 7/16 of an inch in diameter.
- NAS517-5-4 is a screw which is 5/16 of an inch in diameter
- NAS583-8 is 3/16 of an inch in diameter.
- NAS584-8 is 1/4 of an inch in diameter.

Many of the bolts come in families or series with the diameters running in 1 /16 inch increments through the series:

HEX HEAD bolts AN3 thru AN20 have diameters of 3/16 of an inch thru 20/16 or 1-1/4 inches. CLEVIS bolts AN23 thru AN36 . 3/16 of an inch thru 16/16 or 1 inch diameter. FLUSH HEAD 100 degree, high strength, NAS333 thru NAS340 . 3/16 of an inch thru 10/16 or 5/8 of an inch diameter.

These examples give the diameter in 1/16 of an inch. However, for screws there are two other ways in which diameter sizes are given: by screw size or by thread call-

out. Most of the screw sizes you will see in aircraft these days are No. 4, No. 6, No. 8 sizes with National Coarse threads and No. 10 and larger with National Fine threads. These aren't twist drill hole sizes. A No. 4 is approximately 7/64 of an inch in diameter, No. 6 is approximately 9/64 of an inch, No. 8 is approximately 5/32 of an inch, and No. 10 is 3/16 of an inch in diameter.

When the thread callout is used, it specifies the number of threads per inch. It may be either a National Coarse or a National Fine Standard Thread. The difference between the two is the number of threads per inch.

Size	National Coarse threads per inch	National Fine threads per inch
No. 4	40	48 (Not generally used)
No. 6	32	40 (Not generally used)
No. 8	32	36 (Not generally used)
No. 10	24 (Not generally used)	32
1/4	20 (Not generally used)	28

A 10-32 thread callout is therefore a No. 10 screw size having 32 threads per inch. Sizes larger than No. 10 are given in fractions of an inch. Typical examples of screws which indicate the diameter by screw size or thread callout are:

- AN51 5-6-18 screw is a No. 6 diameter.
- AN520-10-18 screw is a No. 10 diameter.
- AN526-832-12 screw is a No. 8 diameter having 32 threads per inch.

RULE NO. 4

LETTERS, IN PLACE OF DASHES, IN THE PART NUMBER FOR A SCREW OR BOLT SIGNIFY VARIATIONS OF THE BASIC PART. When letters follow the basic part number, they refer to the kind of material, the plating or finish of the material, or both. For example:

- AN520B10-48 signifies a brass material with a black oxide finish.
- AN526C1032-4 signifies corrosion-resistant steel.
- AN526DD632-8 signifies aluminum alloy.
- AN515PB4-8 signifies a brass material which is cadmium plated.
- AN515UB4-8 signifies a plain (unplated) brass material.

When letters are used in place of the last dash, they generally refer to the head configuration.

- AN520-10R8 signifies a recessed head (Phillips).
- AN3H7 signifies a drilled head and shank.
- AN3H7A signifies a drilled head only.

These letters certainly tell a story, but the picture gets scrambled when the dashes are left out. Can't they leave the dashes in to make it easier to read?

They can't because the dashes themselves carry a message. The dashes tell you that the part is according to the basic specification. The basic specifications for the screws we have just been talking about call for slotted heads. The letter "R" must be inserted in place of the dash to denote a recessed type head like Phillips.

Practically everywhere you look on airplanes you see screws with Phillips type recesses. Why are they called "variations"? The slots came first and they haven't left yet. A modern version of this turning device is a "dove-tail" (Hi-Torque) slot which enables high torquing of flush head bolts (NAS583 series). Another version of recess is the Torq-Set (modified cross).

NUTS

Most bolts and screws are of little use without a nut. Most bolts and screws are of little use with the incorrect nut. We are including a chart of the nuts most commonly used on the C-130 Hercules and JetStar. We caution you to double check the installation for the correct bolt-nut combination. Remember when a drilled-shank bolt and a self-locking nut did not go together? There are larger sizes of bolts that only come with a drilled shank and are used with castellated or self-locking nuts. However, if a castellated nut is called for, a drilled shank bolt must be used.

Watch that bolt length! Will the nut bottom out on the unthreaded grip portion before it torques down? Will the Dome Nut be ruined because the bolt is too long? Double check!

The fact that some nuts have fiber or nylon inserts while others do not is not the only determining factor for high temperature applications. Temperature limitation is also based on the alloy and finish of the nut. Carbon or alloy steels finished with cadmium plate are usually good up to 450°F. Corrosion resistant steels finished with silver plate usually go up to 800°F. You will find some nuts listed up to 1200°F.

Some nuts use Cetyl Alcohol or other lubricants soluble in the cleaner specified in the nut procurement specification.

Some use no lubricant other than the plating on the nut itself. We refer you to applicable documents and technical manuals for specifics.

In our listing of nuts you will find the smallest and the largest of a series and/or random sampling to assist you in identification. The bolt and screw listings usually show a complete series, such as AN3 through AN8.

Get the right combination of bolt/screw and nut, apply the correct torque, and you should have a good installation. Again, we have not attempted to cover ALL fasteners. We HAVE attempted to show you how to determine the correct fastener.



NATIONAL AIRCRAFT STANDARD HEAD MARKINGS BOLTS AND SCREWS

- Dash denotes corrosion resistant steel.
- - Two staggered parallel dashes denote corrosion resistant steel.
- × Cross denotes alloy steel (125,000-145,000 PSI).
- △ Recessed triangle denotes close-tolerance shank and/or head.
- △ Triangle with a dimple inside denotes close-tolerance shank and/or head, high strength (160,000 - 180,000 PSI).
- Double dash denotes aluminum alloy.
- = This marking on screw and bolt heads denotes bronze material.

CHART NOTES:

Length column gives the incremental change of useful length unless grip length is specified.

BCP denotes Brass-Cadmium plated.

Cad. plated denotes cadmium plated.

CRES denotes corrosion resistant steel.

CSK denotes countersunk.















KSI denotes thousands of PSI (pounds per square inch).

Example: 220,000 PSI = 220 KSI.

NA denotes not applicable.







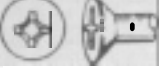
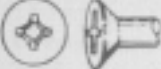

SCP denotes Steel-Cadmium plated.

BOLT IDENTIFICATION CHART



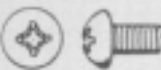
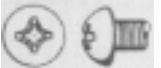
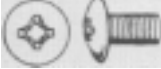

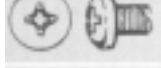
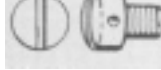

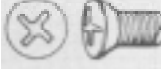
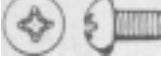
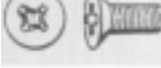
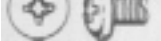



BOLTS	PART NUMBER	NOMENCLATURE	TYPE HEAD	LENGTH INCREMENTS (Inches)	MAX. TEMP. (F)	REMARKS
	AN3 thru AN8	Bolt, Machine, Aircraft	Hex	Grip, 1/16	450	Superseded in some applications by NAS 1103 series. Use in shear applications only. Alloy steel-cad. plated. *
	AN23 thru AN28	Bolt, Clevis	Round Slotted	Grip, 1/16	450	Alloy steel-cad. plated. Shear applications only.
	AN42 thru AN49	Bolt, Eye	Eye	1/8	450 to 800	Steel-cad. plated. "A" after dash number for NO drilled shank. C before dash number for corrosion resistant steel.
	AN173 thru AN178	Bolt, Close Tolerance	Hex	1/8	450	Alloy steel-cad. plated. Shear applications with close tolerance holes. *
	MS21 250	Bolt, 180 KSI. Tension	Ext. Wrenching, 12 point	Grip, 1/16	450	Alloy steel-cad. plated. Tension applications. Code H denotes drilled head. Although grip lengths are designated in 1/16 in. they are available only in 1/8 in. increments.
	NAS1004 thru NAS 1008	Bolt. Machine, Non-Magnetic	Hex	Grip, 1/16	1200	CRES, Heat resistant. Bolts can be procured with drilled heads or shanks, Suffix H denotes drilled heads. No suffix denotes drilled shank only.
	NAS1 103 thru NAS1116	Bolt. Shear	Hex	Grip, 1/16	450	Alloy steel-cad. plated. Suffix D denotes drilled shank. Short thread.
	NAS1202 thru NAS1207	Bolt	100° Flush, Phillips	Grip 1/16	450	Alloy steel-cad. plated. Add D to P/N to denote drilled shank.
	NAS1303 thru NAS1306	Bolt	Hex	Grip, 1/16	450	Alloy steel-cad. plated. Suffix D denotes drilled shank. Suffix H denotes drilled head. Has longer thread than NAS 1 103 series.
	MS20004 thru MS20018	Bolt, 160 KSI Tension	Internal Hex	Grip 1/16	450	Alloy steel-cad. plated. Tension applications. Code H denotes drilled head.
	NAS428	Bolt, Adjusting, Non-Standard	Crowned Hex	1/8	450	Alloy steel-cad. plated. K denotes bolt with slotted shank. H denotes bolt with drilled head. Dash denotes plain bolt.
	NAS464	Bolt, Shear	Hex	Grip, 1/16	450	Superseded in most applications by NAS1103 series.
	NAS501	Bolt	Hex	1/8	450	See NAS1004.
	NAS583	Bolt	100° Flush, Hi Torque Recess	Grip, 1/16	450	Alloy steel-cad. plated. For high strength structural shear applications.

* NOTE: AN3 thru 8 and AN173 thru 178 bolts also available in CRES and aluminum alloy.

SCREW IDENTIFICATION CHART

SCREWS STRUCTURAL	PART NUMBER	NOMENCLATURE	TYPE HEAD	LENGTH INCREMENTS (Inches)	MAX. TEMP. °F	REMARKS
	NAS333 thru NAS340	Screw, Structural	100" Flush Phillips	Grip, 1/8	450	General Use.
	NAS517	Screw	100" Flush	Grip, 1/16	450	Alloy steel-cad. plated. See NAS1203 for lighter weight, short thread screws.
	NAS560	Screw, High Temperature	100" Flush, Phillips	Grip, 1/16	See Remarks	Code H - Corrosion resistant steel A286. Code X - Corrosion resistant steel, inconel X. Use in structural applications of high temperature or non-magnetic. A286-1 200°F; NAS560KH - non-magnetic. NAS560XK = temp. exceeding 1200°F.
	NAS623	Screw, Machine	Pan, Phillips	Grip, 1/16	450	Alloy steel-cad. plated. General structural high strength applications. Short thread shear.
SCREWS NON-STRUCTURAL						
	AN502	Screw, Machine	Drilled Fillister Slotted	1/16	450	Alloy steel-cad. plated, Fine thread. Use where safety wire is required. Use in non-structural applications.
	AN501	Screw Flush	100" Slot or Phillips	1/16	450	Superseded in most installations by NAS 514.
	AN615	Screw	Round	1/16	450	See MS35206.
	AN520	Screw	Round	1/16	450	See MS35207, NAS604, MS35215
	AN526	Screw	Button	1/16	450	Non-structural use such as access plates, dust covers, placards, etc.
	MS35206	Screw, Machine	Pan, Phillips	1/16 up to 1/2 then 1/8	450	Coarse thread. Carbon steel-cad. plated. Use in non-structural applications.
	MS35214	Screw, Machine	Pan, Phillips	1/16	800	Brass - Black Oxide coating. Use in non-structural, non-magnetic, non-glare applications.
	MS35266	Screw, Machine	Drilled Fillister Slotted	1/16 up to 1/2, then 1/8	450	Carbon Steel - cad. plated. Use MS 35206 or NAS600 thru 602 screws unless safety wire is required. Use in non-structural applications.
	NAS1101	Screw, Machine	Flat Fillister Torq - Set	1/16	450	Alloy steel-cad. plated. Code H denotes drilled head, Use in non-structural applications.
	NAS1102	Screw, Machine	100" Flush, Torq- Set	1/16	450	Alloy steel-cad. plated. Use in non-structural applications.
	NAS387	Screw, Machine	100" Oval, Phillips	1/16	450	Steel alloy-cad. plated. Use for interior trim with LS855, KS27129, or NAS 390 finishing washers.
	NAS514	Screw, Machine	100" Flush, Phillips	1/16 up to 1 inch, then 1/8	450	Alloy steel-cad. plated. Use in non-structural applications.
	NAS600 thru NAS606	Screw, Machine	Pan, Phillips	1/16	450	Alloy steel-cad. plated. Use in non-structural applications.











NUT IDENTIFICATION CHART

NUTS	PART NUMBER	SIZE & THREAD	MATERIAL	MAX. TEMP. °F	REMARKS
	AN310-3	0.190-32 UNJF	See Remarks	See Remarks	450°F for SCP nuts. 700°F for passivated CRES nuts. Dash in part number indicates carbon steel; C indicates corrosion resistant steel. These nuts develop the full rated tensile strength of 125 KSI bolts and screws. Do not use in shear applications. See AN320. AN310 interchangeable with AN355 but not vice-versa. Nomenclature: Nut, Plain, Castellated.
	AN310C4	0.250-28 UNJF			
	AN31 5-4	1/4-28 UNF-3B	SCP	See Remarks	Material: Dash indicates carbon steel 4 5 0 °F C indicates corrosion resistant steel, (750°F) Cadmium plated. R = Right hand thread. L = Left hand thread. For IO-32 size see MS 2 1042/2 1043 - Nomenclature: Nut, Plain, Airframe.
	AN315C20L	1-114-12 UNF-3B	CRES		
	AN316-4R	1/4-28 UNF-3B	SCP	450	Use as shear or jam nuts only. These nuts develop 50% of the tensile strength of 125 KSI bolts. Nomenclature: Nut, Check.
	AN316-18R	1.0-18 UNF-3B			
	AN320-4	0.250-28 UNJF	See Remarks	See Remarks	450°F for SCP nuts. 700°F for passivated CRES nuts. Dash in part number indicates carbon steel; C indicates corrosion resistant steel. Do not use with tension bolts, see AN310 nuts. Nomenclature: Nut, Plain, Castellated, Shear.
	AN320C5	0.3125-24 UNJF			
	KFN542-3*	0.190-32 UNJF	SCP	450	Add S for spindle packaged nuts for use with automatic tools. NUT: Alloy Steel. Washer: Carbon Steel. Nomenclature: Nut, 6 Point, Captive Washer. See TLN 1000 series nuts. Shear Type.
	LS35155F08-3	0.164-32 UNJC-3B	SCP	450	These nuts develop the full rated tensile strength of 125 KSI bolts. Lubricant: Cetyl Alcohol. Nomenclature: Nut, Self-Locking, Plate, Curved.
	LS35155F3-4	0.250-28 UNJF-3B			
	MS1 7826-3	0.190-32 UNJF	SCP	250	Body: Alloy Steel. Insert: Nylon or equivalent. Finish: Cadmium Plate. Lubricant: None. Nomenclature: Nut, Self Locking, Non-Metallic Insert.
	MS17826-16	1.000-12 UNJF			
	MS21025-16	1.000-16 UNS	4140 or 8740 Steel, Cadmium Plating	450	Used as bearing retainers where AN320 or AN310 will not meet design requirements. MS21025 nuts can universally replace AN 7502 nuts, but not vice-versa. Nomenclature: Nut, Castellated, Bearing Retaining.
	MS21025-55	3.4375-16 UNS			
	MS2 1042-02	0.086-56 UNJC	SCP	450	These nuts develop the full strength of 160 KSI bolts and screws. Lubricant: Cetyl Alcohol. Nomenclature: Nut, Self-Locking, Non-Corrosion Resistant Steel.
	MS21 042-6	0.375-24 UNJF			
	MS2 1043-04	0.112-40 UNJC	CRES	800	Corrosion and heat resistant steel, silver plate finish. Lubricant: None. Nomenclature: Nut, Self-Locking, Corrosion Resistant Steel.
	MS21 043-6	0.375-24 UNJF			











CONTINUED..

NUT IDENTIFICATION CHART

10

NUTS	PART NUMBER	SIZE & THREAD	MATERIAL	MAX. TEMP. 'F	REMARKS
	MS21047-04	0.112-40 UNJC	SCP	450	Suffix K denotes countersunk or dimpled rivet hole; -6 and -7 not available csk or dimple. MS21 047 is interchangeable with AN362, AN366, NAS680 nuts of like thread and material, but not vice-versa. Nomenclature: Nut, Self-Locking, Plate.
	MS2 1047-3 K	0.190-32 UNJF			
	MS21049-3	0.190-32 UNJF	SCP	450	Suffix K denotes countersunk or dimpled rivet hole. Nomenclature: Nut, Self-Locking, Plate.
	MS21051-06	0.138-32 UNJC	SCP	450	Suffix K denotes countersunk or dimpled rivet hole - not available on -6, -7. Nomenclature: Nut, Self-Locking, Plate.
	MS21051-4	0.250-28 UNJF			
	MS2 1055-06	0.138-32 UNJC	SCP	450	Suffix K denotes countersunk or dimpled rivet hole not available on -6, -7. These nuts develop the tensile strength of 125 KSI bolts and screws. Nomenclature: Nut, Self-Locking, Plate.
	MS2 1055-4	0.250-28 UNJF			
	MS21 057-08	164-32 UNJC	SCP	450	Suffix K denotes countersunk or dimpled rivet holes. Nomenclature: Nut, Self-Locking, Plate.
	MS2 1057-3K	0.190-32 UNJF			
	MS21 059-04	0.112-40 UNJC	SCP	450	All except -6 available with countersunk or dimpled rivet hole. Suffix K indicates csk or dimple hole. Lubrication: Cetyl Alcohol, Nomenclature: Nut, Self-Locking, Plate, Two Lug.
	MS21059-4K	0.250-28 UNJF			
	MS2 1060-06	0.138-32 UNJC	CRES	800	Suffix K denotes countersunk or dimpled holes. Dash 6 not available with csk or dimple. Lubricant: None Nomenclature: Nut, Self-Locking, Two Lug.
	MS21060-4	0.250-28 UNJF			
	MS21083004	0.112-40 UNJC	See Remarks	250	Body: Aluminum Alloy. Insert: Nylon or equivalent. Finish: Aluminum-Anodize or Chemical Film Treatment. Lubricant: None. Intended for shear applications. Nomenclature: Nut, Self-Locking.
	MS21083D6	0.375-24 UNJF			
	MS21 083N04	0.112-40 UNJC	SCP	250	Body: Steel. Insert: Nylon or equivalent. Finish: Cadmium plate. Lubricant: Cetyl Alcohol. Intended for shear applications. Nomenclature: Nut, Self-Locking.
	MS21083N12	0.750-1 6 UNJF			
	MS2 1086-08	0.164-32 UNJC	SCP	450	Suffix K denotes countersunk or dimpled rivet holes - not available on -6. Develops full tensile strength of 125 KSI bolts. Nomenclature: Nut, Self-Locking Plate.
	MS21086-3K	0.190-32 UNJF			
	MS33737-()	6-32	See Remarks	450	Dash number determines over all dimensions. Material: Cage-Phosphor Bronze. Nut - Half-hard brass. Primarily used for front mounting of instruments with NAS 1635-06-CP. Nomenclature: Nut, Self-Locking.



NUTS	PART NUMBER	SIZE & THREAD	MATERIAL	MAX. TEMP. 'F	REMARKS
	MS35426-13	1 0-32	Steel	450	Carbon steel, Cadmium Plated or Commercial Brass. Not Self-Locking. Nomenclature: Nut, Plain, Wing.
	MS35426-2	UNF-2B	Brass	250	
	MS36426-14	1/4-28			
	MS35426-4	UNF 2B			
	MS35426-15	5/16-24			
	MS35426-6	UNF-2B			
	MS35426-16	3/8-24			
	MS35426-8	UNF-2B			
	MS35426-17	7/16-20			
	MS35426-10	UNF-2B			
	NAS509-4	1/4-28 UN F-3B	SCP	N/A	Dash denotes right hand threads. L denotes left hand threads. Use with NAS513 keyed washer for positive locking of rod end terminals to hydraulic piston rods. Nomenclature: Nut, Drilled, Jam.
	NAS509L14	7/8-14 UNF-3B			
	NAS509-24	1-1/2-12 UN F-3B			
	NAS577-17A	1.0-14 UNJF-3B	SCP	N/A	Non-corrosion resistant steel. Lubricant: Cetyl Alcohol. Nomenclature: Nut, Self-Locking, Floating Barrel.
	NAS578-4B	N/A	SCP	N/A	Retainer, Floating Barrel Nut.
	NAS1291 CO2	0.086-56 UNJC	CRES	800	In most applications, superseded by MS21042 & MS21043 series nuts. Nomenclature: Nut, Self-Locking.
	NAS1291C10	0.625-18 UNJF			
	NAS1473A5	0.3125-24 UNJF	See Remarks	-65 to 225	Nut: Steel. Washer: Aluminum or Steel. Seal: Black Rubber. Minimum radial float = 0.020. Maximum radial float = 0.030. Nomenclature: Nut, Self-Locking, Plate, Two Lug, Cap, Floating.
	NAS1474A04	0.112-40 UNJC	See Remarks	-65 to 250	
	NAS1474A4	0.250-28 UNJF			Nut: Steel. Shell: Steel. Washer: Alum. Alloy or Steel. Seal: Black Rubber. Nomenclature: Nut, Self-Locking, Plate, Cap, Floating.
	SS-58310	0.190-32 UNJF	1010 Steel	450	
	SS-58308	0.138-32 UNJC			Non-structural applications only. Not self-locking. Charts must be consulted to determine part number, size, etc. Nomenclature: Tee Nut, Long Prong.
	T2S4600H-064	0.375-24 UNJF	SCP	450	
	T LN 1000-04	0.138-40 UNJF	SCP		Do not use with short thread bolts. Develops the full rated tensile strength of 125 KSI bolts. For use in fuel tanks. Nomenclature: Nut, Self-Locking Plate, Dome.
	T LN 1000-S	0.500-20 UNJC			
	69678-I 032	0.190-32 UNJF	AMS6485, 6487,6304.	-65 to 450	These nuts develop full rated tensile strength of 260 KSI bolts. Lubricant: Cetyl Alcohol. Nomenclature; Nut, Self-Locking, External Wrenching.
	69678-1414	0,875-I 4 UNJC	Alloy Steel.		

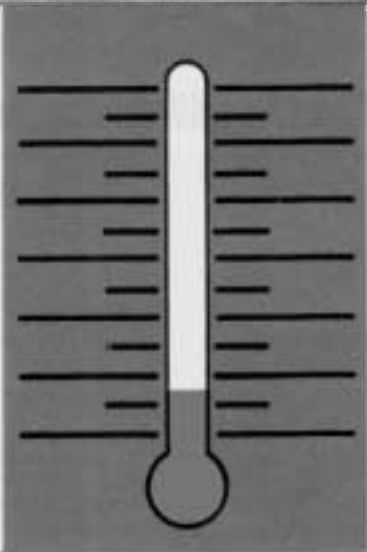

NEW Hydraulic Pump Limits Temperature

by: John Walters, *Design Engineer, Senior*

One of the components being phased into Hercules C-130 production to maintain its up-to-date new airplane status is the Abex engine driven hydraulic pump.

Although new to the Hercules, Abex pumps of similar design have proved their value as standard equipment on other Lockheed airplanes.

The Abex pump is a nine-piston, pressure compensated, variable volume, in-line design with one added feature which makes it unique. It contains an integral temperature sensing device (thermostat) which reduces the pump displacement and pressure before its temperature becomes excessive, thus allowing it to be used interchangeably with either the Vickers or New York Air Brake pumps. More on this later.

Beginning with LAC Serial 4653 all non-USAF Hercules in production will get Abex hydraulic pumps at the four engine positions. The Auxiliary Hydraulic System will retain the electric powered pump previously specified. The Abex part number 66039 · Model AP4V-18 pump

will replace the Vickers PV3-075-4 and the New York Air Brake (NYAB) 66WBD300 Series pumps.

At the customer's option some early 1975 Hercules currently in production (prior to LAC 4653) are getting the Abex pump. Also, there are plans for use of Abex pumps as spare attritional replacements on some Hercules airplanes which were originally equipped with Vickers or NYAB pumps.

Photographs in this article show the three different pumps. While all three have similarities, you can find distinguishing features in the appearance of each to aid in identification. As is customary, the pumps have name and specification plates attached.

The Abex pump is designed to meet U.S. Military requirements of MIL-P-I 9692 whereas the NYAB pump met the requirements of MIL-P-7740. The newer specification is more stringent - particularly in rated speed, rated temperature, endurance, and materials requirements. These improvements are equally meaningful in pump utilization on nonmilitary Hercules airplanes.

12

Abex Hydraulic
Pump on a
Hercules Engine

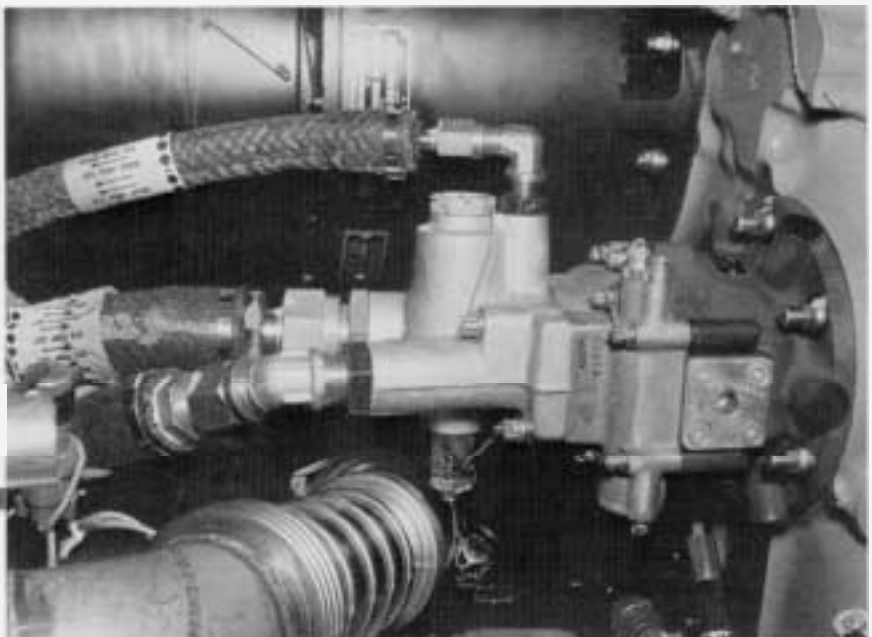



New York Air Brake Hydraulic Pump



Vickers Engine Driven Hydraulic Pump

The main advantages of this Abex pump are:

- (1) Its longer life expectancy which is backed by a failure free warranty from the manufacturer. (Abex furnishes warranty of 6,000 flight hours or six years, whichever occurs first.) This means that any pump which fails for any reason within the warranty period is repaired by Abex free of charge.
- (2) The pump can be used in either a “NYAB System” which requires a run-around case drain circuit, or a “Vickers System” which requires the absence of a run-around case drain circuit – in other words the Abex pump will work on any Hercules with no plumbing changes required.

Demonstrated reliability of the Abex pump design in applications such as the Lockheed C-141 program has revealed that the Mean Time to Unscheduled Replacement (MTUR) for the Abex pump will exceed the MTUR for pumps used previously.

As mentioned earlier, one of the unique features of this pump is its thermostat that limits fluid and pump temperature by reducing pump pressure during isolation when flow through the pump is negligible. By “isolation” we mean that mode of operation when the suction and pressure line shutoff valves (in wing dry bays) are closed, while the engine and consequently the pump is running.

Naturally, more heat is generated by a pump operating at high pressure than by a pump operating at low pressure. When the fluid temperature reaches approximately 250°F (121°C) the thermostat positions the compensator valve to port fluid under pressure to the “decrease-angle” side of the stroking piston, thus reducing pump displacement and pressure. Stabilization of pump operation is achieved before the allowable design temperature of 275°F (135°C) is reached.

This automatic reduction of pressure in the system will occur only while the pump is in isolation because that is the only pump operational mode in which the temperature reaches 250°F. Normal operating pressure is restored almost immediately when the suction and pressure line shutoff valves are opened since suction line flow

across the thermostat cools it, allowing the pump to return to full stroke.

The much longer operational life of the Abex pump significantly improves the ratio of field maintenance man-hours per flight-hour and greatly reduces the chances of cancelled flights due to pump failure.

Overhaul cost per unit for the in-line pump is less than that for others since this design incorporates fewer parts. Total overhaul cost is further reduced because the period between overhaul for the Abex pump is longer than that for other Hercules pumps.

During accomplishment of the checks listed under “Starting Engines” in the Flight Manual, where the pumps are individually placed in isolation in order to determine that each respective pump is operating properly, be cautious that you do not leave any pump in isolation for an extended period of time. Except for a failed pump, do not leave any pump isolated longer than is required to make the prescribed check. The isolation mode is hard on the pump because the inlet is shut off. For optimum pump life, get the pump out of this mode as quickly as possible.

A characteristic of the Abex pump prompts us to include a maintenance tip. This applies when a pump is replaced:

The Bleed Procedure for removing entrapped air from the Abex pump is comparable to that for the Vickers pump in the Hercules hydraulic systems. These are in-line pumps and they must rotate for fluid or air to pass through. Details on eliminating air from the systems are in your Maintenance Manuals. When replacing any engine driven hydraulic pump, the most important single thing that must be done is to fill the pump case to overflowing through the case drain port after installation and prior to operation. This ensures that the pump will initially operate with adequate lubricating hydraulic fluid around bearings and sliding surfaces.

Adding this to your preventive maintenance routine prepares your Hercules for the advantages of the extended life of the newer pumps.



Occasionally we receive field reports of loss of engine oil through venting and/or high oil consumption. Usually the answer to the problem is obvious; sometimes it proves to be a puzzler. As a follow on to last issue's article concerning the external scavenge oil filter installation on the Hercules, we present some troubleshooting hints developed by Mr. C. R. Long of Detroit Diesel Allison.

First, determine if there has been a bearing, gear, or oil pump failure by performing the following steps:

- 14
- Inspect compressor inlet and turbine exit area for presence of oil and damage.
 - Check all magnetic plugs and filters for indications of internal failure.
 - If there is sufficient oil in the engine, motor the engine to see if oil tank quantity increases. Assuming we don't have a simple case of oil sump gravitational flooding, an increase would indicate an abnormal amount of oil remaining in the sumps.
 - If needed, add oil to a safe operating level and start the engine, monitoring oil pressure and quantity. If the sumps were flooded, the engine will smoke and vent oil for the first few minutes. Clam shell doors may be removed to preclude their being coated with oil venting from the turbine inlet casing 3 and 9 o'clock struts.
 - When oil temperature reaches normal, run engine at about 850°C TIT for 5 to 10 minutes. Smoking and venting should return to normal.
 - After engine shutdown (use GROUND STOP, not FEATHER position), remove the bottom power section and reduction gear sump plugs and inspect. Also check for abnormal amount of oil being drained from either location.

NOTE: Abnormal amount of oil from either sump may indicate a failed scavenge pump. Less than a quart is considered normal.

- A feather shut down will usually result in poor scavenging of oil.
- Defective turbine lighthouse seals contribute to oil venting from the turbine inlet casing strut vents.

If there is no indication of pump, gear, or bearing failure, proceed with the following checks:

- Check the scavenge system back pressure. Maximum is 30 PSI. Clean/replace oil cooler, fuel heater, hoses, and/or scavenge oil filter element as necessary to bring the pressure to normal.
- Make a ground run to see if oil consumption/venting is occurring all the time or just at altitude. Sometimes, draining all the oil, sumps, cooler, lines, etc., and refilling with new oil will solve the problem. Contaminated or mixed oil, or oil that has lost its anti-foaming characteristics may be the problem.
- If the problem appears to be altitude related, replace, as necessary, the oil tank pressurizing valve (old valve P/N 697218-1 set at 3.5 \pm 0.5 PSI, new valve P/N 697218-3 set at 5 \pm 0.5 PSI), or the oil tank filler cap seal; and check the upper portion of the oil tank for cracks.
- During flight, determine if the problem of oil venting is related to air speed and/or attitude (nose high).

NOTE: If venting occurs during or soon after takeoff regardless of attitude or altitude, the reduction gear prop shaft seal is suspect.

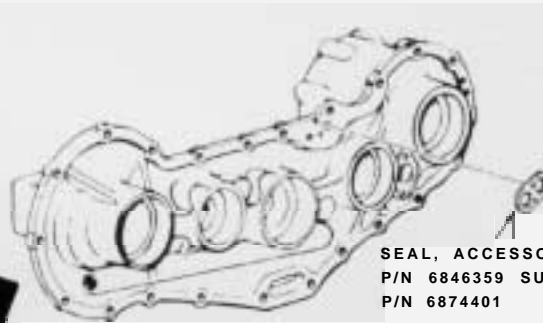
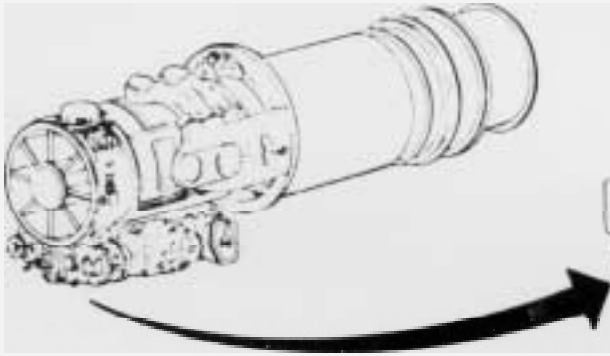

SEAL, ACCESSORY HOUSING
P/N 6846359 SUPERSEDES
P/N 6874401

REAR VIEW
Accessory Drive Housing Cover

NOTE:

The metal encased seal, P/N 6846359, is incorporated in the following Power Section serials: T56-A-1 5LFE, AE109624 and up; 501-D22A. AE550289 and up; T56-A-15, AE109526 and up.

- If venting occurs in a nose high attitude, the reduction gear main scavenge pump may have failed or the front turbine scavenge oil tube may have been improperly mated during hot section reassembly; either case is rare.
- If venting or oil loss occurs at higher altitude, the power section main oil pump may be at fault. This could be due to excessive internal clearance or inefficiency of the scavenge element due to a restriction in the scavenge element back vent, resulting in cavitation of the scavenge element.

There are other less likely causes of venting such as a cracked internal diffuser scavenge oil tube which requires a depot level repair; and, just recently, cases of failure of the two port seal (scavenge/pressure) between the accessory cover and housing. Failure of the pressure seal on the outer perimeter will permit oil to go directly to the sump



and be vented overboard through the gang drain. (Consult Allison CSL-I 5 10 and CSL-1032 for repair instructions.)

We believe these troubleshooting procedures will help you in determining where your oil went.

SERVICE NEWS

CORRECTIONS:

Vol. 2, No. 1, page 13. . .the callouts for the steps were reversed – see correct callout below.

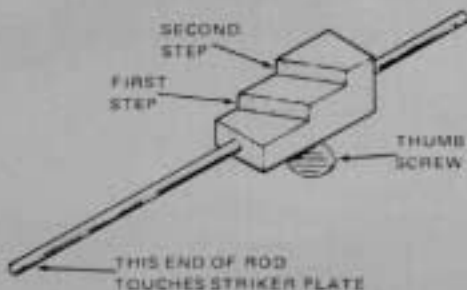

Vol.2, No. 2, page 13, 3rd. paragraph under RECOMMENDATIONS, 4th. sentence, the recommended concentration volume percentages should read...at a volume of 0.1 to 0.15% Biobor JF

CUSTOMER SERVICE DIVISION
LOCKHEED-GEORGIA COMPANY
A DIVISION OF LOCKHEED AIRCRAFT CORPORATION
MARIETTA, GEORGIA, 30063



JetStar
JetStar
JetStar
JetStar
JetStar

LOOK TO LOCKHEED FOR LEADERSHIP