

VOL. 7, NO. 3, JULY - SEPTEMBER 1980

# *SERVICE NEWS*

A SERVICE PUBLICATION OF LOCKHEED-GEORGIA COMPANY, A DIVISION OF LOCKHEED CORPORATION



# service news

A SERVICE PUBLICATION OF  
LOCKHEED-GEORGIA COMPANY  
A DIVISION OF  
LOCKHEED CORPORATION

**Editor**

Charles 1. Gale

**Associate Editors**

James A. Loftin

Steve Palmer

William H. Shepherd

Patricia A. Thomas

*Art Direction & Production*

Anne G. Anderson

Vol. 7, No. 3, July - September 1980

## CONTENTS

### 2 Focal Point

C. H. Dallas

Chief Design Engineer

### 3 C-130 Technical Publications

How the Lockheed technical manuals are prepared, and what publications are available to Commercial and Military Hercules aircraft operators.

### 10 MLG Manual Gearbox

Proper operating technique in the shifting process.

### 13 Shock Strut Servicing

New charts, and changes in methods of servicing.

### 19 StarTip

Another Crease Great Improvement

**Cover:** This Indonesian Hercules aircraft is used to support the government's transmigration program. The Hercules transports thousands of people from the larger cities to the less populated islands of Indonesia.

Published by Lockheed-Georgia Company, a Division of Lockheed Corporation. Information contained in this issue is considered by Lockheed-Georgia Company to be accurate and authoritative; it should not be assumed, however, that this material has received approval from any governmental agency or military service unless it is specifically noted. This publication is for planning and information purposes only, and it is not to be construed as authority for making changes on aircraft or equipment, or as superseding any established operational or maintenance procedures or policies. The following marks are registered and owned by Lockheed Corporation: "Lockheed", "Hercules", and "JetStar". Written permission must be obtained from Lockheed-Georgia Company before republishing any material in this periodical. **Address all communications to Editor, Service News, Department 64-22, Zone 278, Lockheed-Georgia Company, Marietta, Georgia, 30063. Copyright 1980 Lockheed Corporation.**



C. H. Dallas

## FocalPoint

The successful operation, maintenance, and overhaul of our products is dependent upon the information provided by our technical manuals. The support of our products is of utmost importance to us at the Lockheed-Georgia Company, and our Engineering Service Publications Division is a vital part of this support. We are dedicated to bringing to our customers accurate, complete, and easily understood information for operation and maintenance at all levels.

Preparing and maintaining all of the engineering service publications for our aircraft and equipment is a substantial task. Some concept of the scope of our activity can be obtained by being aware of the number of volumes and pager required for the C-130, L-100, C-141, C-5, and the JetStar aircraft. The service publications for these aircraft consist of 4960 volumes of more than 1,000,000 pages of text and illustrations. During the past four years, we have been computerizing all the new and changed manuals in order to reduce the cost of preparation and updating. We expect that this will enable us to better serve you -our customer.

Beginning on page 3 of this issue, there is an article about our technical publications group, and what is involved in producing technical material. In future *Service News* issues, there are plans to include short articles on how to use these manuals and other technical publications.

We welcome your inputs concerning the service publications at any time, either directly to our Engineering Service Publications Division, or through our Lockheed Field Service Representatives.

Sincerely,

C. H. Dallas  
Chief Engineer - Design

## PRODUCT SUPPORT

LOCKHEED-GEORGIA COMPANY  
MARIETTA, GEORGIA 30063

T. J. Cleland

Director

CUSTOMER  
SERVICE  
DIVISION

O. L. BRAUND  
DIRECTOR

INTEGRATED  
LOGISTICS SUPPORT  
DIVISION

J. L. THURMOND  
DIRECTOR

CUSTOMER  
SUPPLY  
DIVISION

M. M. HODNETT  
DIRECTOR

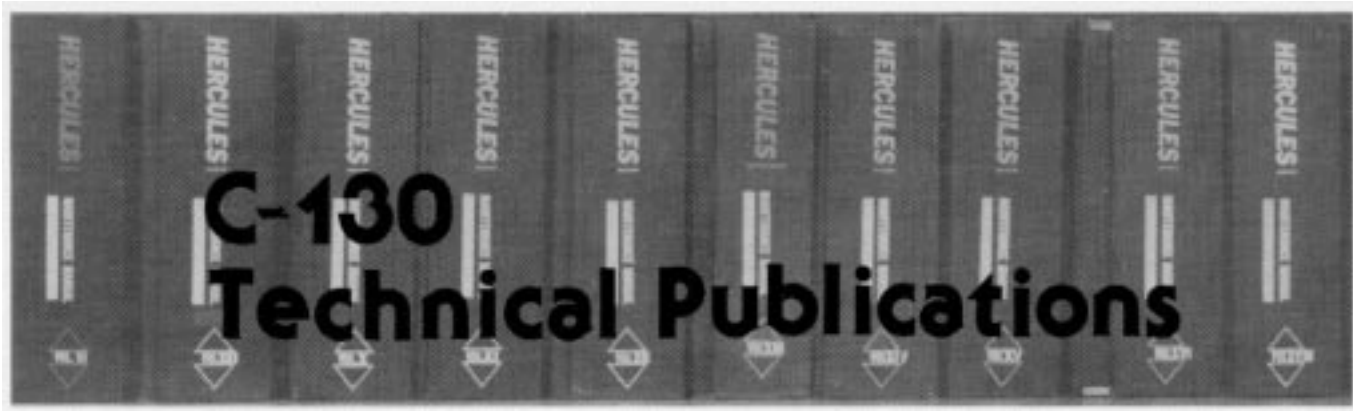

***Prepared to provide the customer with detailed instructions on the safest and most efficient methods of operating and maintaining the Hercules aircraft.***

---

***by W. H. Hoeing, Manager,  
Aircraft Publications Department***

Manuals of various types are provided to a customer who buys a new car, a tractor, or a bicycle. These manuals tell the customer how to operate, maintain, and inspect the product. When spare parts are available, information is supplied on how to order the parts.

Lockheed feels very strongly that with an air vehicle which is, by comparison, much more complex and costly, our C-130 Hercules customers must be given the best that we can produce in the way of technical manuals to support the airplane. Explicit instructions detailing the safest and most efficient methods of operating and maintaining the airplane are what you expect to be provided, and the reputation of the C-130 depends on your having that information – current with delivery of your airplane. It is our intent to prepare technical manuals that will provide all of the information necessary to achieve that.

On a few occasions we have received inquiries about translating our technical manuals into foreign languages. It is our current policy not to undertake such translations. While we understand that many of our customers need to have manuals written in their native language, we feel that they can do a more thorough job of translation than we could. Each of our customers is far better able than we to translate our manuals into the language usage of his own people. If we attempted translations, we would also be concerned about the possibility of losing, or altering, some of the technical meaning of the material.

#### Some Insights on How Publications Are Prepared

Just by way of providing you with a bit of background about our Engineering Service Publications Division, our sole purpose is to prepare and obtain the technical data that is needed to support the products of Lockheed-Georgia. The experience level of our people is extensive – most have been with Lockheed 20 years or more – and

we are dedicated to the preparation of high-quality publications. Our technical writers have a wealth of experience and training in engineering and in the techniques required for the proper field operation and maintenance of our airplanes. The artists who prepare our illustrations are also equally skilled. We provide a mixture of text material and illustrations in our manuals that we feel will best present to the user the descriptive and procedural information that he needs.

In the process of preparing a new manual, our technical writers make use of all the engineering drawings, and associated interim data that are used by our factory personnel to produce and check out the airplane. A good deal of the information that is needed in the manuals, however, doesn't appear in any of the engineering documentation. For this reason our writers have to maintain close contact and coordination with the people in other organizations who are specialists in the various disciplines of airplane systems in such areas as design, the development of ground support equipment, human engineering, safety, flight operations, structures, loads, aerodynamics, etc.

After the initial writing and illustrating phase of a new or updated manual has been completed, it is checked to assure that it is technically accurate, and that none of the information necessary for the customer to adequately maintain the airplane has been overlooked. Each of our flight manuals is subjected to a detailed and critical review by a committee which is composed of design, aerodynamics, and flight operations experts who are most capable of determining whether or not the manual will give the customer's flight crew the best possible basis for safe and efficient operation of the airplane. The aircraft manuals that cover maintenance, inspection, structural repair, cargo loading, etc., are reviewed by the appropriate system designers who review them for accuracy and completeness.



**The technical writers gather all the information necessary to prepare the text of the manuals.**

The quality assurance process doesn't stop there. After any needed technical corrections resulting from the review of the manuals have been made by the technical writer, the publications are systematically reviewed by our team of technical editors. Their review is to make sure that nothing has been missed by the writer or the reviewers that might cause doubt or misunderstanding.

Finally, the procedural information, such as removal and replacement, operational checkout, adjustment, and rigging is actually used on an airplane to prove that the job can be done in the way it is described in the instructions.

The material, which has been in draft form thus far, is now ready for the conversion to printed manuals and delivery to the customer. This in itself is a somewhat involved task, during which continuing checks are made of the material when it is typed in final form to ensure that errors are not introduced and that the quality of the printed material is up to our standards. In this process we are making increasing use of computers, and we expect that this evolutionary process will continue as we find newer and better ways to get our job done.

We have been talking generally about the "airframe" manuals – those that are used to operate the airplane and perform flight line maintenance. Much the same process is followed in developing for our customers manuals that are necessary for shop maintenance and repair of airplane systems, for overhaul of airplane system components, and for operation, maintenance, repair and overhaul of ground support equipment. In those instances where manuals of this nature have been prepared for the U. S. Air Force or Navy, we buy copies of the manuals and make them available to our customers. If the system, component, or ground support equipment is not used by the U. S. Military services, then we either obtain commercial publications from the equipment manufacturer or, if the hardware is designed and built by Lockheed, prepare the manuals ourselves. Regardless of the source of the data, it is not delivered to one of our customers until we have reviewed it and satisfied ourselves that it is suitable for its intended purpose.

There is one other very important publication – the Service Bulletin. Service Bulletins describe inspections that are required and provide information on how to

**Technical artists use their talents to best illustrate the written text.**







**The editing and publishing group now uses the most up-to-date computerized equipment to prepare the manual material for printing.**



change your airplane or airplane associated equipment. If it is urgent that the information in the Service Bulletin get to you as rapidly as possible, it is identified as an “Alert” bulletin. The Alert Bulletin is first sent out by teletype (TWX). It is then replaced with a printed copy which is printed on blue paper so that it is easily recognizable.

Inspection-type Service Bulletins tell you why the inspection needs to be made, what airplanes or equipment are to be inspected, how soon you should do it, what to look for, and what to do if you find something that needs to be corrected.

Modification-type Service Bulletins provide you with all the information needed to make some change in the configuration of your airplane or equipment. These bulletins may be either “detailed” or “record”. The detailed bulletin includes all of the step-by-step instructions with illustrations necessary for making the change. Record bulletins include a list of the engineering drawings, a list of the necessary parts, and other related documentation that is needed to accomplish the modification.

#### Why Publications Should Be Maintained

A novice in this business might think that once a set of technical manuals has been prepared to cover a customer’s airplane, or airplanes, it would be good forever. We know, however, that such is not the case. Even though the Hercules has now been in operation for more than twenty-five years, we learn something new about it almost every day. At the time of publication of this article, there will be forty-six countries around the world in which the Hercules is in use. Experience has taught us that we are apt to learn something new about the airplane with each new customer and the variety of missions that it is used for. This educational process involves not just the flight manual, but the maintenance manuals, repair manuals and all others as well. Much of the knowledge we gain needs to be passed along to all our customers in the form of changes and revisions to manuals previously published.

Some examples of the types of things that result in the need for continuing changes to technical manuals are:

- After closely observing Hercules operations over a long period of time in areas that are normally very hot, sandy and dusty, we realized the need to develop operating techniques that would minimize the wear and tear on engines, propellers, air conditioning systems, flight controls, etc. This information has been included in the current versions of our flight manuals. Use of these procedures will result in longer airplane life and lower maintenance costs if you are in those atmospheric conditions with any degree of frequency.

- We recognized that the procedures in the maintenance manuals for bleeding the hydraulic systems were too complicated and time-consuming. The procedures have been simplified and can be accomplished in less time.

- Some of our customers told us that certain of our structural repairs could only be accomplished by highly qualified personnel and required materials and shop facilities that were not readily available to them. This led us to revise SMP 583, Structural Repair Manual, to give alternate repairs wherever possible that will eliminate the problems.

- Every now and then we find that suppliers of components, such as valves, pumps, actuators, instruments, etc. decide not to manufacture that component any longer. Or, we may find a source for a better or equally good but less expensive substitute. While operation and maintenance of the system with the new component installed may not be any different, your Illustrated Parts Catalog should be updated to show the new part number as an

alternate replacement part, or preferred spare. Also, different technical manuals need to be provided for repair and overhaul of the new component.

### Modernization and Hardware Improvements

While the Hercules aircraft that just came off the production line may be very similar in outward appearance to the very first one, they are very different airplanes. Lockheed is continually looking for ways to modernize and improve the airplane. As changes are decided upon, they are introduced into the continuing production “baseline” airplane. These hardware changes also require that the technical manuals be changed to agree with the airplane so that when you buy a new airplane, the manuals that you get with it accurately reflect the airplane configuration. Some of the changes that are made in production are also suitable to be installed on airplanes that have been delivered to our earlier customers. A little more discussion of this lets us revert to the subject of Service Bulletins, and of the need to make corresponding changes in your technical manuals.

Some time ago we made a change in production airplanes to replace the 20-cubic inch hydraulic fuse in the emergency brake line with a 10-cubic inch fuse and also to install a 10-cubic inch fuse in the normal hydraulic brake line. This was done to limit the hydraulic fluid loss in the event that a hose or brake assembly developed a leak. The change was suitable for installation on airplanes that had already been delivered to our customers, so Customer Engineering Change Proposal (CECP) Number 262 was sent to all our customers to advise them of the availability of kits to modify their airplanes. The proposal letters included the price for the kits and Service Bulletin and a separate price for the manuals changes that needed to be made to show the modified systems. In this particular case the Flight Manuals, Maintenance Manuals and Illustrated Parts Catalogs were affected, and the manuals needed to be available to the flight crews and maintenance people for use on modified airplanes.

Sometimes you receive Service Bulletins that may require that inspections be made on your airplanes or that recommend a modification be made for which Lockheed does not furnish the parts. These Service Bulletins are sent to all of our customers at no cost. If these Service Bulletins affect our standard baseline airplane manuals (as opposed to customer peculiar technical manuals), these manuals are changed as necessary and copies of the altered pages are sent to any customer to whom we are contractually obligated to furnish such material.

The foregoing is a thumbnail sketch of the types of things that cause technical manuals to change and Service Bulletins to be issued. As I’m sure you can see, technical publications are dynamic, and the safety and efficiency of your operation is related to a great degree on the currency of your publications.

### Commercial Airplane Publications

We provide a different set of technical manuals for the operators of our commercial airplanes than those that are used for our foreign military customers. This is because:

- The commercial airplane is different in many respects from the military airplane.
- The manuals for the commercial airplanes are formatted in general accordance with Air Transport Association (ATA) specifications. The military airplane manuals are more closely related to U.S. military specification manuals.

The manuals that are currently furnished to the buyer of a commercial airplane are:

AFM 382/E/G – This is the FAA-approved Airplane Flight Manual for 382, 382E, and 3826 airplanes. The manual includes airplane operating limitations, normal operating procedures, emergency operating procedures and performance data for takeoff and landing. It is a serialized manual that is applicable to all airplanes of these models.

\*OM 382E (or OM 382G) - XXC – These are airplane Operating Manuals, which contain an expanded normal operating checklist, system descriptions and system operation. Separate, tailored, Operating Manuals are prepared for each customer to provide the information needed for his airplane configurations. We use this approach to avoid the need for the flight crew to sift through a mass of various airplane serialized material that is not applicable to the airplane being flown.

SMP 1118 – This manual provides the 382E and 382G airplane performance data for climb, cruise, and descent.

SMP 515 – The maintenance Program Plan gives the Lockheed recommended, and FAA approved, inspection and overhaul periods for baseline airplanes. Part I of the manual provides the inspection requirements for “A”, “B”, and “C” inspection intervals. Part II comprises the component maintenance program. This part of the manual gives the overhaul and inspection check periods for major aircraft components. Part III is the structural inspection program, which defines the major structural inspection requirements to be performed each 12,600 flying hours. Part IV lists maintenance checks and special inspections which are dictated by special or unusual conditions. Part V includes component data, such as overhaul times, vendor and part number, quantity per airplane, location, description, function, etc.

SMP 515 covers all the commercial models of the Hercules.

SMP 515A – The Inspection Procedures Manual gives the sequential steps for performing “A”, “B”, and “C” inspec-

\* The Xs indicate numbers to be assigned to specific customers.

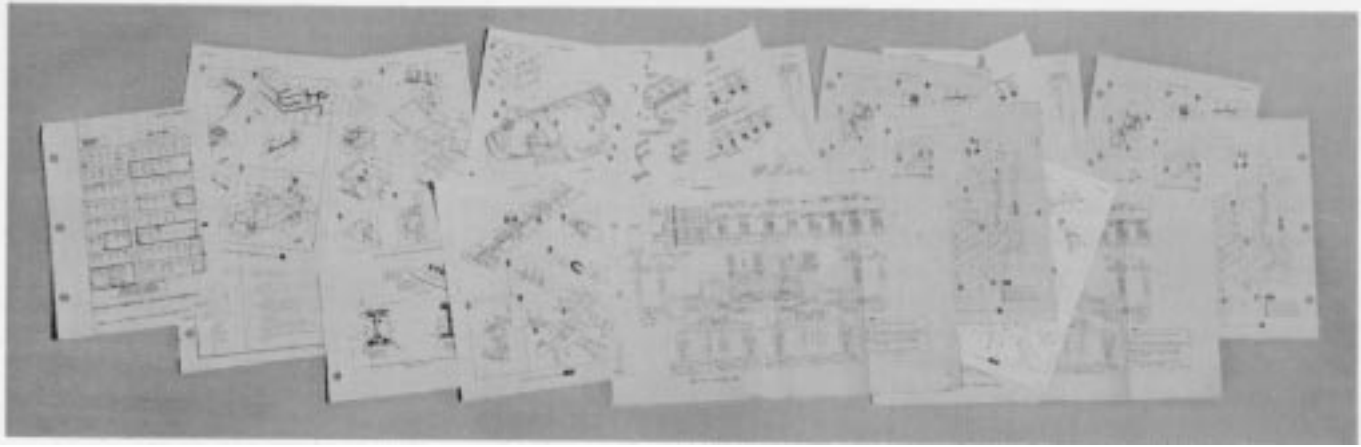

tions. It also provides the procedures for the structural inspection to be performed at 3400, 6300, 9450, and 12,600 flying hours.

This manual is applicable to all the commercial models of the Hercules.

SMP 515C – The Progressive Inspection Procedures Manual is provided to our foreign operators of commercial certificated airplanes.

Besides including inspections and checks to be performed on a daily basis and at turnaround, the manual includes 24 inspection work packages, each of which is to be done at the expiration of 37% flying hours, so that all 24 packages are completed every 900 flying hours. The inspections may be used on an isochronal (calendar span) basis.

The manual also includes the procedures for structural inspections to be performed at 3400, 6300, 9450, and 12,600 flying hours and special inspections which are to be performed under special or unusual conditions.

SMP 515E – This is an Illustrated Tool and Equipment Manual which identifies all of the special tools and test equipment required for maintenance and inspection of the airplane. The manual is arranged in accordance with the chapter sequence under Specification ATA 100.

SMP 521 – The Weight and Balance Manual gives the instructions that are necessary to calculate the weight and balance of the airplane as modifications to the airplane are made or as equipment is removed, installed or re-located.

SMP 581 – The Hercules Maintenance Manual provides the maintenance procedures required for the airplane. The manual is prepared in the chapter sequence dictated by Specification ATA 100 and it is a serialized manual that is applicable to all the commercial airplanes.

SMP 582 – The Wiring Diagram Manual includes all of the wiring diagrams that are applicable to all commercial airplanes.

SMP 583 – This is the Structural Repair Manual which illustrates and defines the airplane structure and provides both general repair procedures and specific repair procedures as applicable to various structural areas.

SMP 850 – The Overhaul Manual is a compilation of individual overhaul manuals which are applicable to repairable components of the airplane.

SMP 1203 – This manual provides the instructions for installation, rigging, maintenance and inspection of the cargo handling systems.

SMP 1206 – This is the Illustrated Parts Catalog for the cargo handling systems.

\* SMP (XXXX) – This is an Illustrated Parts Catalog for the airplane. The manual illustrates all of the replaceable parts of the airplane and gives the ordering data necessary to obtain parts. The manual is customized for each customer and carries a distinctive number.

#### Foreign Military Airplane Publications

During the early years of sales of the C-130 to foreign military customers we relied on U. S. Air Force Technical Orders (T.O.s) to provide all of the technical manuals coverage for these airplanes. Years ago, we saw the need to provide Lockheed-developed manuals to replace most of the U.S. Air Force T.O.'s. The reason was twofold:

The Air Force T.O.'s are in a constant state of change to reflect serialized coverage for later version airplanes and modifications that may or may not be applicable to our foreign customer's airplanes.

■ After all Air Force airplanes have been modified to incorporate a certain change the obsolete data is removed from the T.O.S. Our foreign customers who rely on the continuing Air Force T.O. changes could thus unknowingly delete coverage from their sets of T.O.'s that is still applicable to their airplanes which were not modified.

We feel that the Lockheed manuals are much better suited for use by our military customers than are the Air Force

T.O.'s, and we're continuing the conversion process; but more about that later.

These are the manuals that we now use to support foreign military aircraft programs:

\*FM 382C-(X)D – This is the Lockheed Flight Manual that is used for our foreign military customers. The manual provides all of the information, except performance data, that is necessary for the flight crew to safely and efficiently operate the airplane. A separate, customized manual is prepared for each customer so that he will not have to separate the information that is applicable to his airplanes from coverage of systems and equipment that he does not have.

\* FM 382C-(X)D-CL-1, -2, and -3 – These are the pocket-size flight crew checklists for the pilots, navigators and loadmasters. They include the step-by-step sequence of operational steps required for both normal and emergency conditions.

SMP 777 – This manual includes all of the airplane performance data necessary to satisfactorily plan and accomplish an airplane mission.

SMP 515C – The Progressive Inspection Manual includes the inspections and checks to be performed on a daily basis and at turnaround. It also includes 24 inspection work packages, each of which is to be done at the expiration of 37% flying hours, so that all 24 packages are completed every 900 flying hours. The inspections may be used on an isochronal (calendar span) basis. The manual also includes the procedures for structural inspections to be performed at 3400, 6300, 9450 and 12,600 flying hours and special inspections which are to be performed under special or unusual conditions.

SMP 515E – This is an Illustrated Tool and Equipment Manual which identifies all of the special tools and test equipment required for maintenance and inspection of the airplane.

TM 382C-2-1 through TM 382C-2-13 – The maintenance manuals are serialized, so that they apply to all airplanes and all customers. The individual volumes of the manuals each deal with a different type of airplane system, such as power plant, hydraulic system, flight controls, etc. TM 382C-2-13 deals with the tanker version of the airplane and its aerial refueling system, so this manual is only given to those customers who operate tanker airplanes.

\*TM 382C-(X)D – This is a separate, customized, maintenance manual that is prepared for each customer to give the maintenance procedures needed for systems installed on a customer's airplane that are different from those on a baseline airplane.

SMP 1223 – This manual supplies maintenance techniques to be applied to combat the corrosive effects of

sand and dust on airplanes that are normally operated in that kind of an atmosphere.

SMP 583 – This is the Structural Repair Manual which illustrates and defines the airplane structure and provides both general repair procedures and specific repair procedures as applicable to various structural areas.

TM 382C-9 – This manual gives the instructions for the rigging, inspection and maintenance of the cargo handling system. It also provides the procedures for onloading, tying down and aerial delivery or off-loading of cargo, as well as the procedures for paratroop of personnel.

TM 382C-18B-01 – This manual lists all of the publications that are available for operation, flight line maintenance, field level maintenance and overhaul of the baseline airplane and the equipment installed on the airplane. It also lists manuals that are applicable to the airplane support equipment.

\*TM 382C-(X)D-01 – This manual supplements TM 382C-18B-01. It lists the publications that are applicable to the systems that are installed on a customer's airplane that are different from those on a baseline airplane.

\* SMP (XXXX) – This is the Illustrated Parts Catalog for the airplane. The manual illustrates all of the replaceable parts of the airplane and gives the ordering data necessary to obtain parts. The manual is customized for each customer.

#### Air Force T.O.'s Used With Foreign Military Airplanes

All of the manuals that have been described above have been prepared by Lockheed for the use of our foreign military customers. There are some instances, however, where we still use the Air Force T.O.'s, and supply copies of these manuals with the airplanes. Some of these Air Force manuals will be replaced with Lockheed manuals as we set up programs for the conversion. As an example, in July of this year we expect to publish a Power Package Buildup Manual, TM 382C-10, to replace the Air Force T.O. IC-130(H)H-10 that is now being used for this purpose.

Listed below are the Air Force T.O.'s that are currently being furnished to our foreign military customers:

T.O. IC-130(H)H-10 – The Power Package Buildup Manual gives the step-by-step procedures to follow to start with a "bare" engine as manufactured by Detroit Diesel Allison and install all of the components to arrive at a Quick Engine Change (QEC) unit ready for installation on the airplane.

The manual also includes an Illustrated Parts Catalog for the QEC and a numerical listing of all of the component parts.



T.O. IC-130A-06 – The Work Unit Code Manual establishes a system of code identifications that can be used for any type of maintenance action on the airplane, its installed systems, or components. By accumulating maintenance data based on the work unit codes, the customer can gather data as necessary to tell him the time being used for various maintenance functions, system reliability, parts usage, etc.

T.O. IC-130A-21 ~ The Equipment Inventory List provides the basis for a customer system to track the items of equipment that are installed on, or have been removed from, an individual airplane. It gives a method for continuously monitoring the configuration of the airplanes and for maintaining an inventory of the parts that comprise the airplane systems.

T.O. IC-130A-23 – The Corrosion Control Manual gives the information necessary for treatment of the airplane to prevent corrosion or to remove corrosion that has already occurred.

T.O. IC-130B-6CF-1 – The Functional Checkflight Procedures Manual provides the method for performing a functional checkflight of an airplane as might be required after certain types of maintenance have been performed. The functional checkflight is for the purpose of determining that the airplane systems that were disturbed have been returned to an acceptable condition.

T.O. IC-130B-6CL-1 – The Functional Checkflight Checklist is used to record data obtained in the process of performing a functional checkflight.

T.O. IC-130B-6WC-3 – These are work cards, set up to define the work to be performed by each mechanic in assigned work areas, for engine buildup, installation and inspection.

T.O. IC-130E-5 – The Basic Weight Checklist and Loading Data Manual gives the instructions that are necessary to calculate the weight and balance of the airplane as modifications to the airplane are made or as equipment is removed, installed or relocated.

#### Publications Revision Service

All of our airplane production contracts include requirements for providing all the types of technical manuals to be furnished with the airplanes and the number of copies of each manual that the customer requires. The contract also defines the period of time during which the manuals will be maintained. This is usually in terms of months after delivery of the airplane, or after delivery of the last airplane.

It is our policy to make sure that our customers are immediately notified of any information that comes to our attention that could affect the safety of flight of

their airplanes or have a critical impact on maintenance procedures. As we have explained earlier in this article, however, there is an abundance of new operation and maintenance data that becomes available for inclusion in the technical manuals that is not of a safety- or maintenance-critical nature. In order to have the means for supplying this material to our customers, we offer all our customers a technical manual revision service. The service can be contracted for on either a one-year or two-year basis, whichever best suits your needs. During the period of the contract you will automatically receive changes and revisions to your technical manuals to keep them up-to-date. The revision service proposals are individually prepared to address themselves to your manuals, and we believe that the service is the best and most practical way to assure yourself that **you** have current data available.

If you have not yet received one of our Technical Manual Revision Service proposals, and would be interested in such a service, drop a note to:

Service Publications Division  
Lockheed-Georgia Company  
86 South Cobb Drive  
Marietta, Georgia, 30063

#### Let Us Know

There are several ways in which you can help us to help you. If you have any suggestions, comments, recommendations for changes or questions, we want to know about them. We know that those of you who live with the airplane on a day-to-day basis have a lot to offer in the way of first-hand experience, and we welcome your input.

9

If you have a Lockheed Field Service Representative, give him your input and he'll see that your queries get back to us. If no rep is available, use the same address that's given above for Revision Service inquiries.

We are also anxious to know that you received Service Bulletins that have been mailed to you and when you have completed a Service Bulletin modification or inspection on any of your airplanes. These Service Bulletins provide you with information we believe you need to have and it makes us uncomfortable when we don't receive confirmation that you have received them. As far as letting us know about your compliance with a Service Bulletin is concerned, we need to keep track of the configurations of airplanes after they are delivered. This information is frequently necessary to us when considering the design of additional modifications that may be appropriate for the same area of the airplane.

Also, please let us know of any errors we may have in the addresses that we use for mailing publications to you, or of address changes that take place. Data that winds up in the Dead Letter Office, or that gets returned to us by the Postal Service, isn't doing anybody any good, and something that you didn't get might hurt you.



# MLG manual gearbox

by C. R. Bush, *Design Engineer Specialist*

Good operator technique is a crucial ingredient in the proper operation of the main landing gear (MLG) manual gearbox on Hercules aircraft. Burred and distorted teeth on the input shaft and slide gear of the manual gearbox have been experienced recently on several C-130E and later model aircraft. Gearboxes manufactured both by Calco and Western Gear Corporation have been Involved\*, and in nearly all cases the damage has been attributed to improper operator technique in the shifting process between manual and hydraulic drive.

Let us take a look at the shift mechanism and its operation to see how this kind of damage may occur.

The manual gearbox contains a hydraulically released, spring applied, uplock brake, and a shift mechanism used

for selecting normal hydraulic drive or manual handcrank drive to activate the main landing gear (Figure 1).

The shift mechanism is composed of three in-line external splines and a slide gear with an internal spline. The slide gear couples the center output spline with either the hydraulically driven Input spline or the manual input spline .

In the normal hydraulic drive position, the slide gear couples the output spline with the hydraulically driven input spline, the manual T-handle and engage cable are positioned "in", and engagement is maintained by a compression spring in the shift linkage on the Calco gearbox, and a tension spring on the Western Gear gearbox.

## Shifting From Hydraulic To Manual Drive

Here is the proper sequence of events which occurs when changing from hydraulic to manual drive: When the hydraulic pressure is depleted, the brake springs engage the brake, locking the hydraulic input shaft to the case.

The manual drive engage T-handle, located on the forward wheel-well bulkhead, is rotated counterclockwise to its stop and then pulled straight out until it locks. This pulls the gearbox lever down, compresses or stretches (depending on the design) the spring in the linkage, and shifts the slide gear so that the output spline is coupled to the manual input spline.

It may be necessary to rotate the manual drive stub shaft (adjacent to the T-handle) to align the spline teeth so that the T-handle can be pulled out and the shift accomplished.

**CAUTION:** The T-handle must not be forced out. To do so may result in damage to the system.

## Shifting From Manual To Hydraulic Drive

In order to shift from manual to hydraulic drive, the following technique is recommended: The T-handle is unlocked by rotating it slightly clockwise with light finger pressure, then pushed in. This slacks the cable to the gearbox lever and permits the spring in the shift linkage to shift the slide gear so that the output spline is coupled to the hydraulic motor-driven input spline. However, if the

View of right-hand wheel well forward bulkhead,

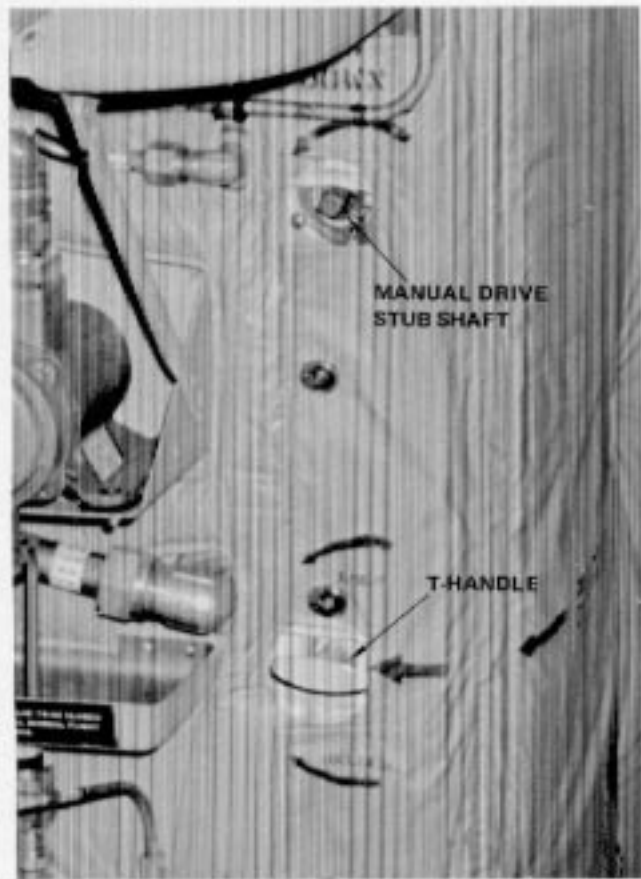

10

\* MLG manual gearboxes manufactured by Calco were used instead of Western Gear units on Hercules aircraft with serial numbers 4548 through 4865. Western Gear gearboxes will again be used on aircraft from serial number 4866 up. C-130A and B models use a different gearbox, to which this article does not apply.

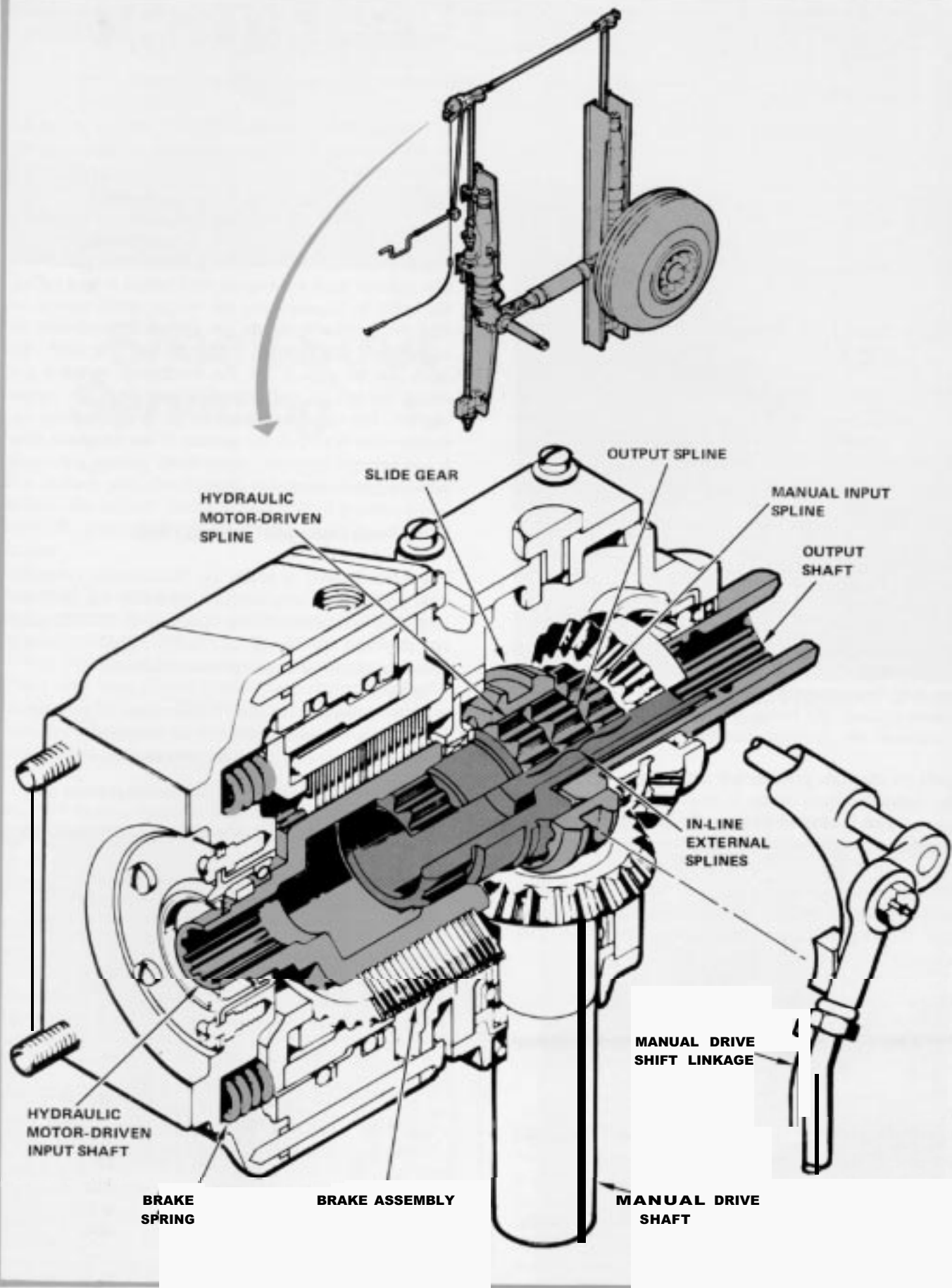
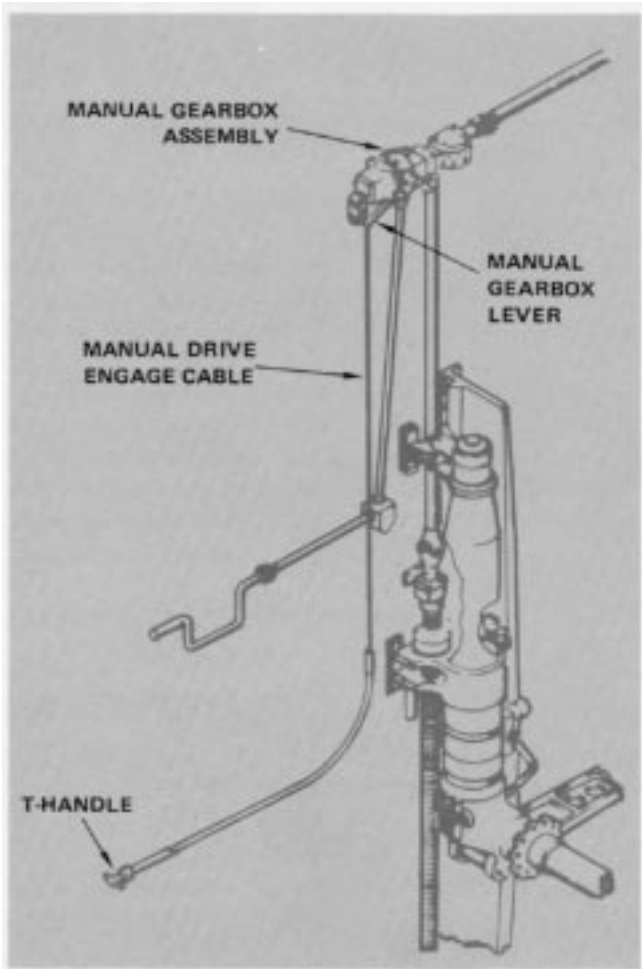

Figure 1. MAIN LANDING GEAR GEARBOX AND UPLOCK BRAKE



**Figure 2. T-HANDLE CHECK**

teeth on the slide gear are not aligned with the teeth of the hydraulic input spline, it is necessary to rotate the manual drive stub shaft to align the teeth and permit the spring to accomplish the shift.

Completion of the shift to hydraulic drive is then verified by turning the stub shaft one turn in each direction. The shaft should turn smoothly and very little force should be required.

Hydraulic pressure can then be restored.

**CAUTION:** Restoring hydraulic pressure prior to shift completion can result in damage to the spline teeth.

If the shift has not been completed (indicated by free rotation of the stub shaft noted above) before hydraulic pressure is restored to the landing gear motor, the brake will be released and the hydraulic input spline will spin while the slide gear is pressed against it by force of the spring. This will cause a ratcheting noise and burrs and deformation of the spline teeth. If damage is severe enough, hydraulic drive engagement may not be possible. Two other conditions can also lead to this type of damage:

1. **Stopping a free-falling gear by pushing in the T-handle-**The results are the same as before. The only difference is that the output spline and slide gear are turning and the hydraulic input spline is stationary.

2. **Pulling the T-handle while the aircraft is on the ground-** During normal gear extension, the gear is driven down until the hydraulic motor stalls out. This generates a slight amount of wrap-up in the torque shafts. When the aircraft lands, the friction washers lock the ballscrews and also lock in the wrap-up of the torque shafts. When hydraulic pressure is depleted, the gearbox brake applies and also locks in shaft wrap-up. If the T-handle is then pulled, the brake is bypassed and the torque shafts unwrap so that the splined teeth are not aligned for hydraulic re-engagement. By applying torque to the stub shaft, the teeth can be aligned, but the mechanism spring is not strong enough to shift the slide gear with this torque applied. The only positive means of re-engaging the hydraulic drive is to jack the aircraft. If the hydraulic drive is not engaged properly, spline tooth damage will occur when hydraulic pressure is restored.

#### MLG Manual Engagement T-handle Check

The T-handle used to engage the MLG manual extension drive is also subject to mechanical binding due to corrosion. This corrosion buildup occurs in the flexible cable assembly and is prone to accumulate rapidly in aircraft operating in adverse environmental conditions.

In order to ensure that the T-handle cable is free to shift the gearbox to manual drive in an emergency, periodic checks may be conducted as follows (see Figure 2):

1. Disconnect the cable from the manual gearbox lever.
2. Operate the T-handle several times to ensure freedom of operation.
3. Reconnect the cable to the manual gearbox lever.

**NOTE:** Do not operate the main landing gear manual sys-

**T-handle when the aircraft is resting on the main landing gear without first disconnecting the cable from the manual gearbox lever. The aircraft must be on jacks for ground operation of the manual T-handle with the cable attached to the manual gearbox lever.**

Binding cable assemblies should be replaced since there is no provision for lubrication of a defective cable assembly. Consult the appropriate Hercules maintenance manual for removal and installation of MLG manual emergency cables.

Using the techniques outlined in this article and a little care in the shift process, you can help make the MLG manual gearbox last practically the life of the aircraft.



## Shock Strut Servicing

The landing gear shock struts are designed to properly cushion the aircraft during landing and all ground operations. To accomplish this, the struts must be properly serviced.

Lockheed has responded to questions from Hercules aircraft operators about the proper servicing of landing gear struts by making in-depth studies of the problems involved. Our studies have resulted in the adoption of new charts and changes in the preferred and alternate methods of servicing the struts. The Hercules maintenance manuals have recently been revised to include the new charts and servicing instructions.

A quick check chart is included in the new servicing information to enable maintenance personnel to determine quickly and without a pressure gage if a main landing gear (MLG) strut requires servicing. This type of chart works well for the MLG, since it is relatively insensitive to cg location, but is not practical for the nose gear.

To use the MLG quick check chart (Figure 1), determine the gross weight of the aircraft. Next, select the curve that corresponds to the applicable extended strut pressure for the particular aircraft. Use this curve to find where the curve intersects the selected gross weight line. Locate the correct "X" distance directly below the intersecting point at the bottom of the chart. The "X" distance (Photo A) is the distance between the bottom of the strut gland nut and the center of the MLG jack pad fitting upper hole. If the difference between the "X" distance as indicated on the quick check chart, and the actual "X" distance measured on the aircraft is less than 1/8 inch, the strut does not require servicing.

13

The "X" distance measurements discussed in this article are taken at the points indicated below in photographs A and 6.

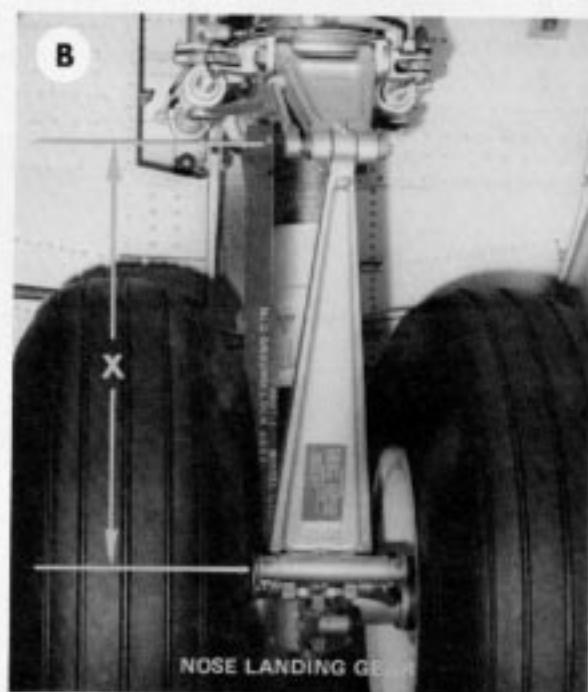
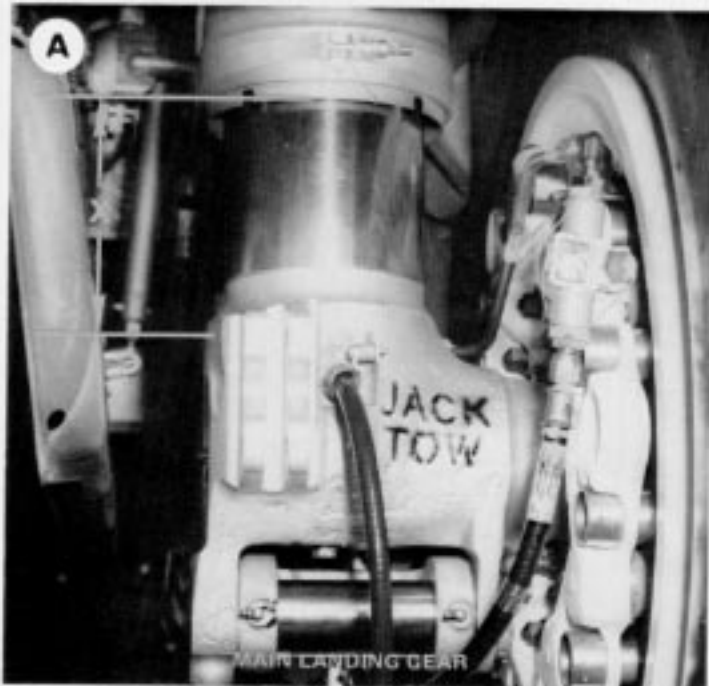



# MLG Quick Check Chart

## To Determine If Strut Servicing Is Required

Extended Strut Pressure	Struts and use conditions
185 P.S.I.G.	C-130A, C-130D-6 for all conditions
215 P.S.I.G.	C-130B(E)/H-type and 382 series (L-100) aircraft with standard struts and a gross weight below 155,000 pounds.
250 P.S.I.G.	C-130B-type aircraft with standard struts for substandard runways.
285 P.S.I.G.	C-130E/H-type and 382 series (L-100) aircraft with standard struts for substandard runways or a gross weight above 155,000 pounds.
450 P.S.I.G.	C-130E/H-type and 382 series (L-100) aircraft with P/N 388058-9 or 19 "soft" struts for all conditions. C-130B-type aircraft with P/N 370438-21 "soft" struts for all conditions.

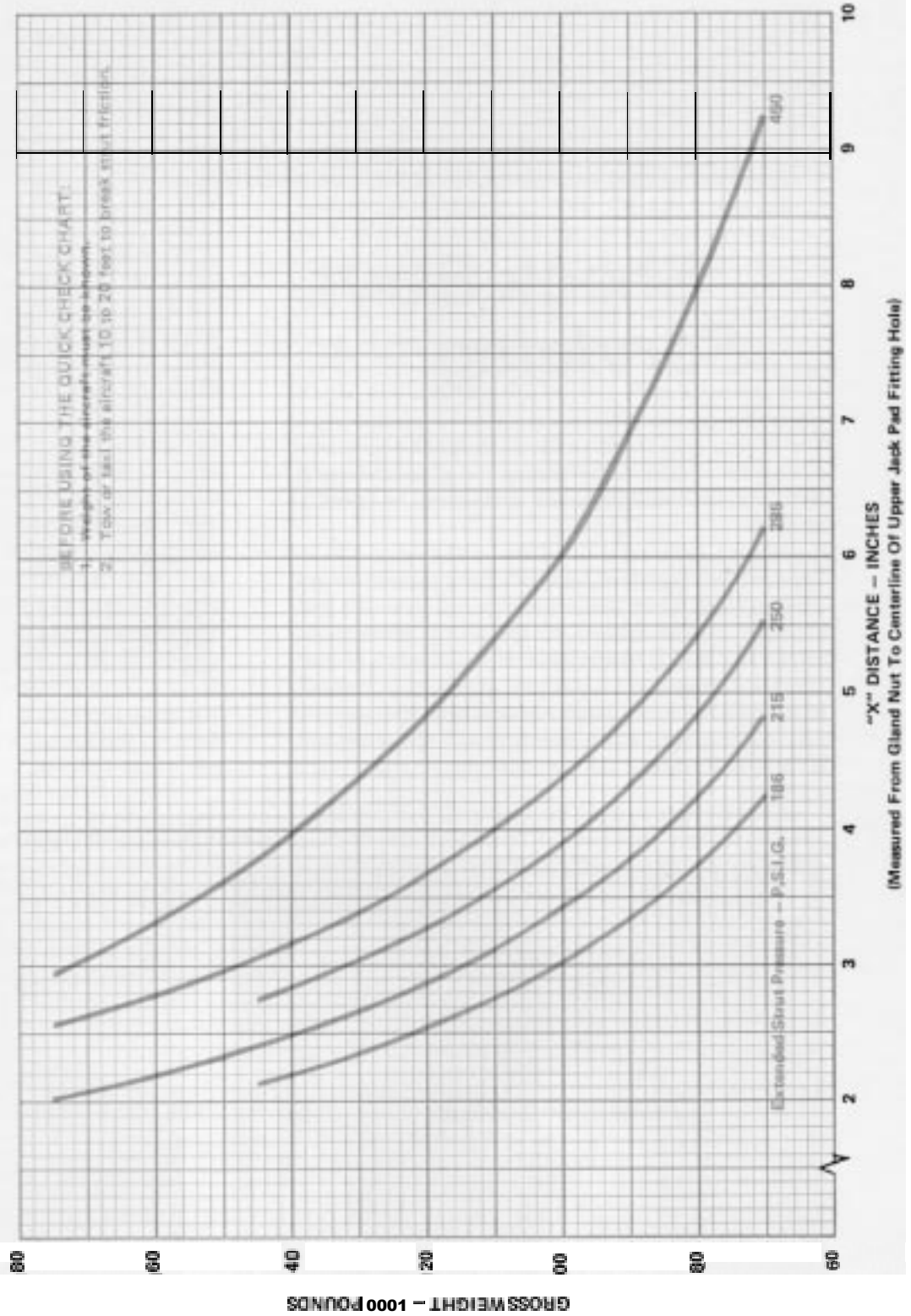

Figure 1. MLG QUICK CHECK CHART

# MLG Strut Servicing

## On-Ground Servicing

PREFERRED METHOD Aircraft On Jacks		
Extended Strut Pressure	Struts and use conditions	Struts and use conditions
186 P.S.I.G.	C-130A, C-130D-6 for all conditions	
215 P.S.I.G.	C-130B/E/H-type and 382 series (L-100) aircraft with standard struts and a gross weight below 155,000 pounds.	C-130E/H-type and 382 series (L-100) aircraft with standard struts for substandard runways or a gross weight above 155,000 pounds.
250 P.S.I.G.	C-130G-type aircraft with standard struts for substandard runways. C-130D (Sk-I) aircraft for all conditions.	C-130E/H-type and 382 series (L-100) aircraft with P/N 388058-9 or 19 "soft" struts for all conditions. C-130B-type aircraft with P/N 370438-21 "soft" struts for all conditions.
		285 P.S.I.G.
		450 P.S.I.G.

### ALTERNATE METHOD - Aircraft Not On Jacks

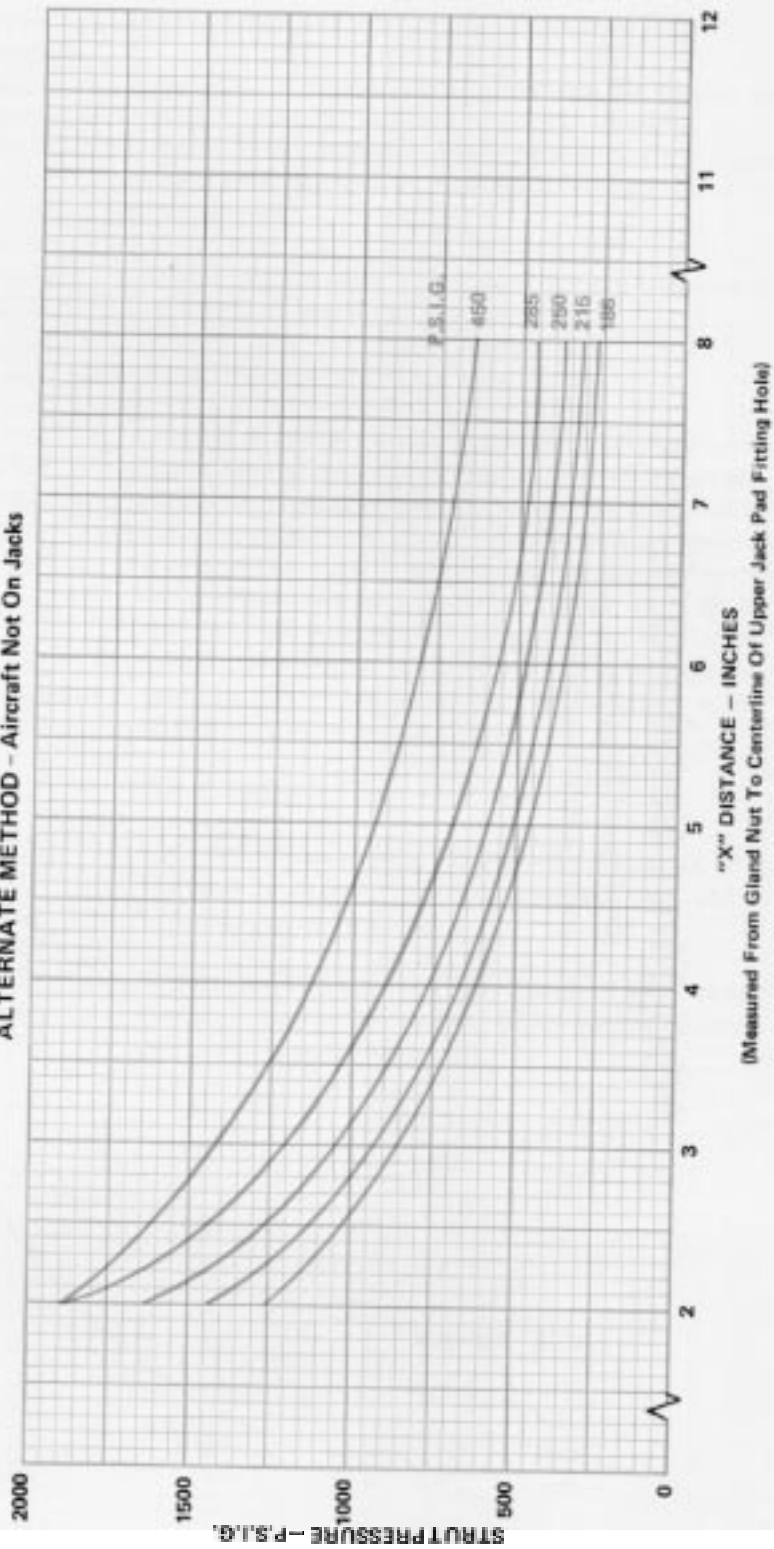

Figure2. MLG STRUT SERVICING CHART -On-Ground Servicing

# NLG Strut Servicing Chart

## On-Ground Servicing

(ALL MODELS AND ALL CONDITIONS)

**PREFERRED METHOD:** Service to 300 P.S.I.G. with airsoft on jacks and with the strut extended.

**ALTERNATE METHOD:** Service in accordance with this new landing gear servicing chart and with the airsoft not on jacks. Use the "Preferred Method" of service at the next subsequent maintenance period.

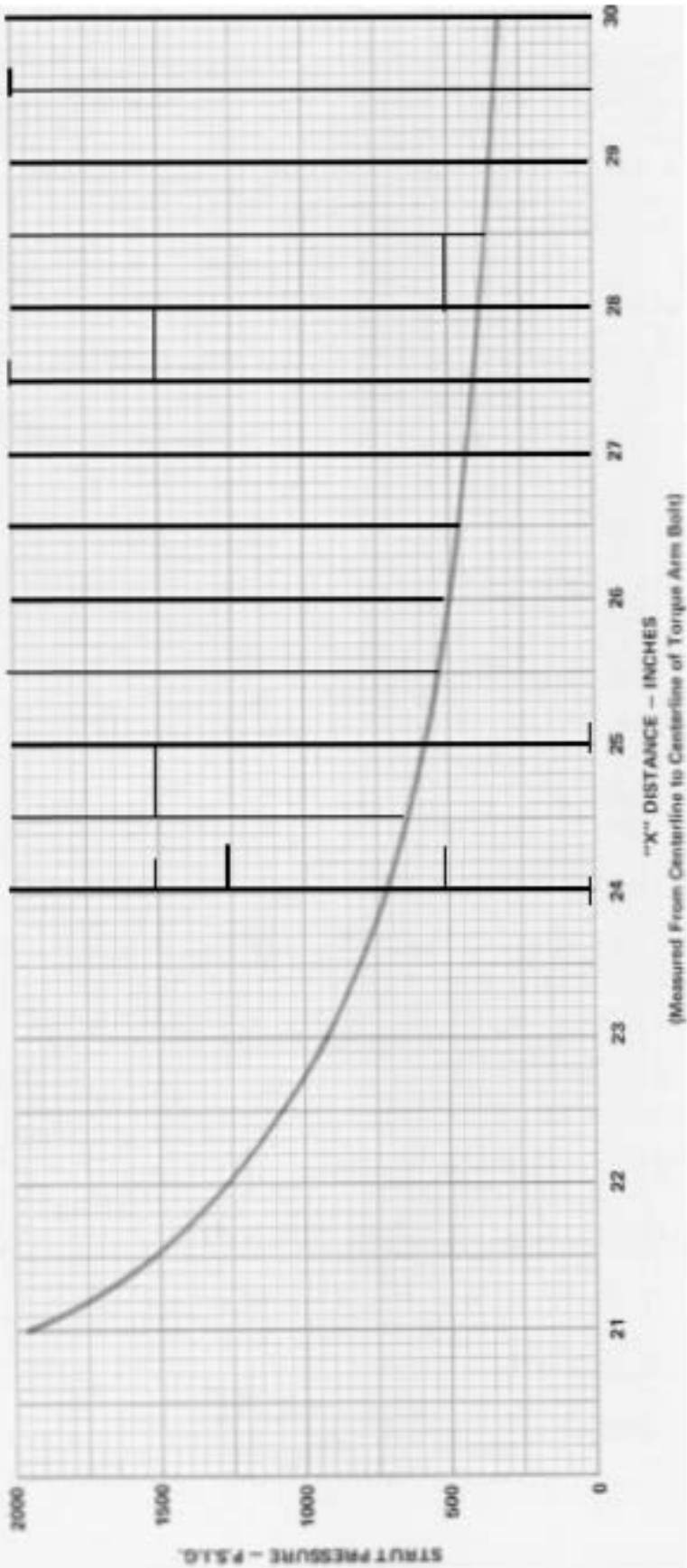

Figure 3. NLG STRUT SERVICING CHART – On-Ground Servicing

## NEW SERVICING CHARTS

### MLG Strut Servicing Chart for On-Ground Servicing

A new chart for on-ground servicing has been developed to allow direct readings of strut pressure and "X" distance without the double interpolation required when using the strut placards. This chart (Figure 2) is used to determine which of the extended strut pressures would be correct for the particular combination of Hercules aircraft model, strut type, and condition involved. Note that the main strut pressures for C-130B-type aircraft have been increased to prevent strut bottoming problems. The chart is also used to determine the recommended MLG strut pressure and "X" distance for servicing the MLG struts with the Hercules on the ground.

To use the MLG strut servicing chart for on-ground servicing, determine from the chart the recommended extended strut pressure for the applicable Hercules. Find the curve corresponding to the selected extended strut pressure. Service the MLG shock strut to a pressure and "X" distance that corresponds to the curve.

*Example:* For a C-130A, the 186 psig curve would be the correct one to use. If the particular C-130A being checked has a strut pressure of 1000 psig, its "X" distance should be 2-1/2 inches  $\pm$  1/8 inch.

### NLG Strut Servicing Chart for On-Ground Servicing

A nose landing gear (NLG) strut servicing chart (Figure 3), has been developed. In this chart, a single curve is used to find the recommended strut pressure and "X" distance for on-ground servicing of NLG struts of any Hercules aircraft. A single curve is used since an extended strut pressure of 300 psig is applicable for the NLG of all Hercules

aircraft under all conditions. This chart is used in the same manner as the MLG strut servicing chart for on-ground servicing.

### THE PREFERRED METHOD – Aircraft on Jacks

Servicing the Hercules MLG struts with the aircraft on jacks is preferred because this method eliminates the inflation errors caused by static friction that sometimes occur when the struts are serviced with the aircraft on the ground.

NOTE: All cautions and warnings of the maintenance manual must be followed.

### Strut Deflation

Jack the aircraft in accordance with the applicable maintenance manual until the wheels are free of the ground. Clean the servicing valves to prevent entry of dirt, and deflate the struts in accordance with the applicable maintenance manual. After the air pressure is depleted, remove the servicing valve from the strut and fully compress the strut with an axle jack. The approximate "X" distance with the strut fully compressed is 1 inch for the main gear strut, and 20-1/8 inches for the nose gear strut, as illustrated in Figures 4 and 5.

### Filling the Strut

With the servicing valve removed, fill the struts with approved hydraulic fluid as required until the fluid is level with the servicing hole.

Replace the servicing valve, taking care to avoid thread damage. Torque to the proper value specified in the applicable maintenance manual.

17

Figure 4

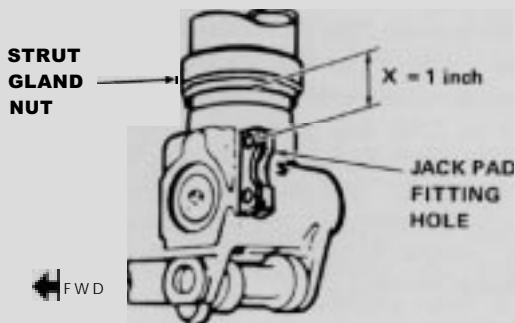

MAIN LANDING GEAR

Figure 5

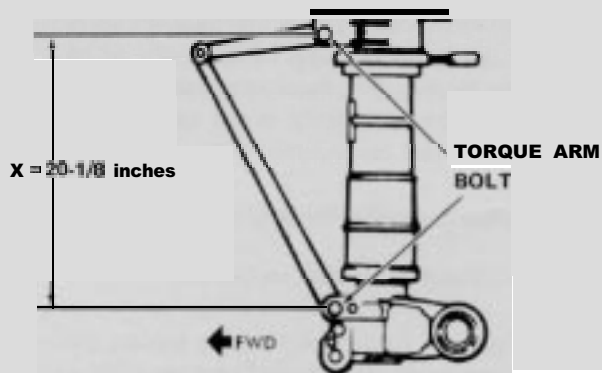

NOSE LANDING GEAR

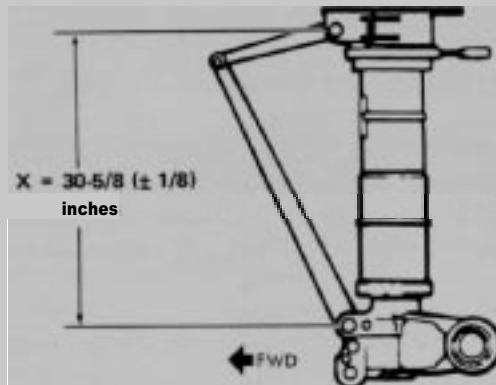

**NOSE LANDING GEAR**

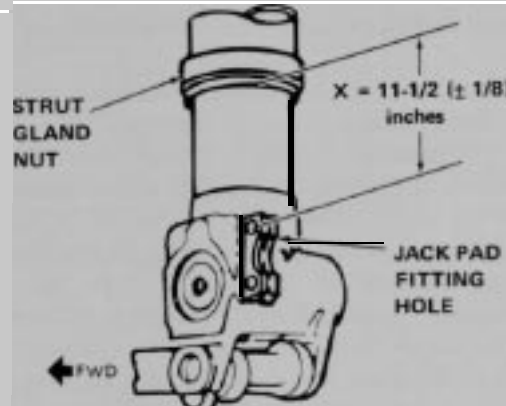

**MAIN LANDING GEAR**

Figure 6

Figure 7

Lower, and then remove the axle jacks to allow the shock strut pistons to extend.

### Strut Inflation

After checking the shock strut fluid level and adding hydraulic fluid as needed, strut inflation can be accomplished. Inflate the NLG strut to 300 psig  $\pm$  10 pounds with the strut fully extended, using a P/N EIST34T684 air-filling chuck, and a P/N 7CAD-337110 gage assembly or its equivalent.

After strut inflation, the NLG “X” distance should be 30-5/8 inches  $\pm$  1/8 inch, measured between the center lines of the torque arm bolts, as illustrated in Figure 6.

Inflate the main gear struts to the appropriate extended strut pressure for the applicable aircraft type, struts, and conditions as listed in Figure 2. The inflated “X” distance for the MLG strut should be 11-1/2 inches  $\pm$  1/8 inch, measured between the bottom of the gland nut and the centerline of the jack pad fitting upper hole, as shown in Figure 7.

After inflating the landing gear shock strut, make certain that the servicing valve is properly closed and torqued. Tighten the servicing valve cap securely using your fingers.

Lower the aircraft and remove the jacks and jack fittings.

### ALTERNATE METHOD - Aircraft on Ground

The aircraft -on-ground method of servicing landing gear struts is the alternate method because of possible inflation errors due to strut static friction. For this reason, the aircraft should be reserviced with the aircraft on

jacks (the preferred method) at the next convenient maintenance period.

### Strut Deflation

Before proceeding with shock strut deflation, make certain that personnel and equipment are clear of the aircraft. This will prevent the possible damage or injury in case of sudden collapse of a strut.

Tow or taxi the aircraft in a straight line 10 to 20 feet prior to parking and deflating shock struts (unless this was accomplished before the aircraft was parked). Failure to do this can result in binding struts, which can affect servicing accuracy.

Clean the servicing valve to prevent dirt or other materials from entering and deflate the shock strut.

### Filling the Strut

Remove the servicing valve from the shock strut. Be certain not to remove the filler standpipe from the NLG strut or the standpipe adapter from a soft-type main gear strut. If it has been removed, reinstall before servicing the strut with oil. The “X” distance with the strut deflated is 1 inch for the MLG strut and 20-1/8 inches for the NLG strut, as previously shown in Figures 4 and 5.

Service the shock strut with approved hydraulic fluid as required until the fluid is level with the servicing hole, and carefully replace the servicing valve to avoid thread damage. Torque the servicing valve as specified in the maintenance manual.

### Strut Inflation

After making certain that the strut fluid level is correct,



attach an approved air-filling chuck and gage assembly. Inflate the strut, using an approved high-pressure dry air or dry nitrogen source.

**Nose Landing Gear** – The NLG strut is to be inflated to the pressure and “X” distance indicated in the Nose Gear Strut Servicing Chart for On-Ground Servicing (Figure 3). The NLG strut “X” distance, as previously discussed, is measured between the center lines of the torque arm bolts.

**Main Landing Gear** – After selecting the extended strut pressure curve that is applicable to the type of aircraft, struts, and conditions, use the curve to determine the specific recommended strut pressure and “X” distance.

Inflate the MLG strut to the correct pressure and “X” distance indicated in the Main Gear Servicing Chart for On-Ground Servicing (Figure 2) . The MLG strut “X” distance, as previously noted, is measured from bottom of the gland nut to the center line of the jack fitting upper hole.

The strut pressure tolerance is  $\pm 10$  psig, although for the sake of simplicity this is not shown on the strut servicing charts.

Following inflation of the strut, make sure that the servicing valve is closed properly and that the valve cap is tightened securely (finger tight).

#### SERVICING TIPS

The following landing gear shock strut servicing tips should be helpful.

- To prevent strut contamination, the filler valve area of the strut should be cleaned before the struts are serviced.

- All safety precautions outlined in the technical manual should be observed when servicing the shock struts. This will help prevent damage to equipment and injury to personnel.

- Under no circumstances should the strut air servicing valve be removed prior to completely exhausting the air pressure from the strut.

- Some soft-type main gear struts use a standpipe adapter between the strut and the servicing valve to control the oil level. This adapter should not be removed when servicing the strut with oil.

- When servicing the shock struts using the aircraft-on-ground method, the aircraft should be moved 10 to 20 feet in a straight line prior to parking. This will help prevent binding or torsional loads that could alter servicing.

The proper use of the new shock strut servicing information and procedures should ensure Hercules operators of increased success in landing gear shock strut servicing, while decreasing aircraft downtime.



#### Another Grease – Great Improvement

There have been quite a few comments that MIL-G-23827A grease was not only lubricating the surface to which it was applied, but was also causing the paint to dissolve. Another grease is now recommended, MIL-G-81322, which will not strip the paint or cause corrosion. Nor will this grease cause the O-rings to swell, which has been one of the characteristics of the other grease. The MIL-G-81322 grease has reportedly saved many man-hours previously used to apply new paint to parts of the aircraft. ■

#### CORRECTION:

In the “Tools for Panelocs” article, V7N2, there is an error on page 18. Figure 2 should show that 1/4 inch is to be taken off the type of screwdriver illustrated, rather than 1/8 inch as indicated. ■

**Beauty may be only skin deep -**

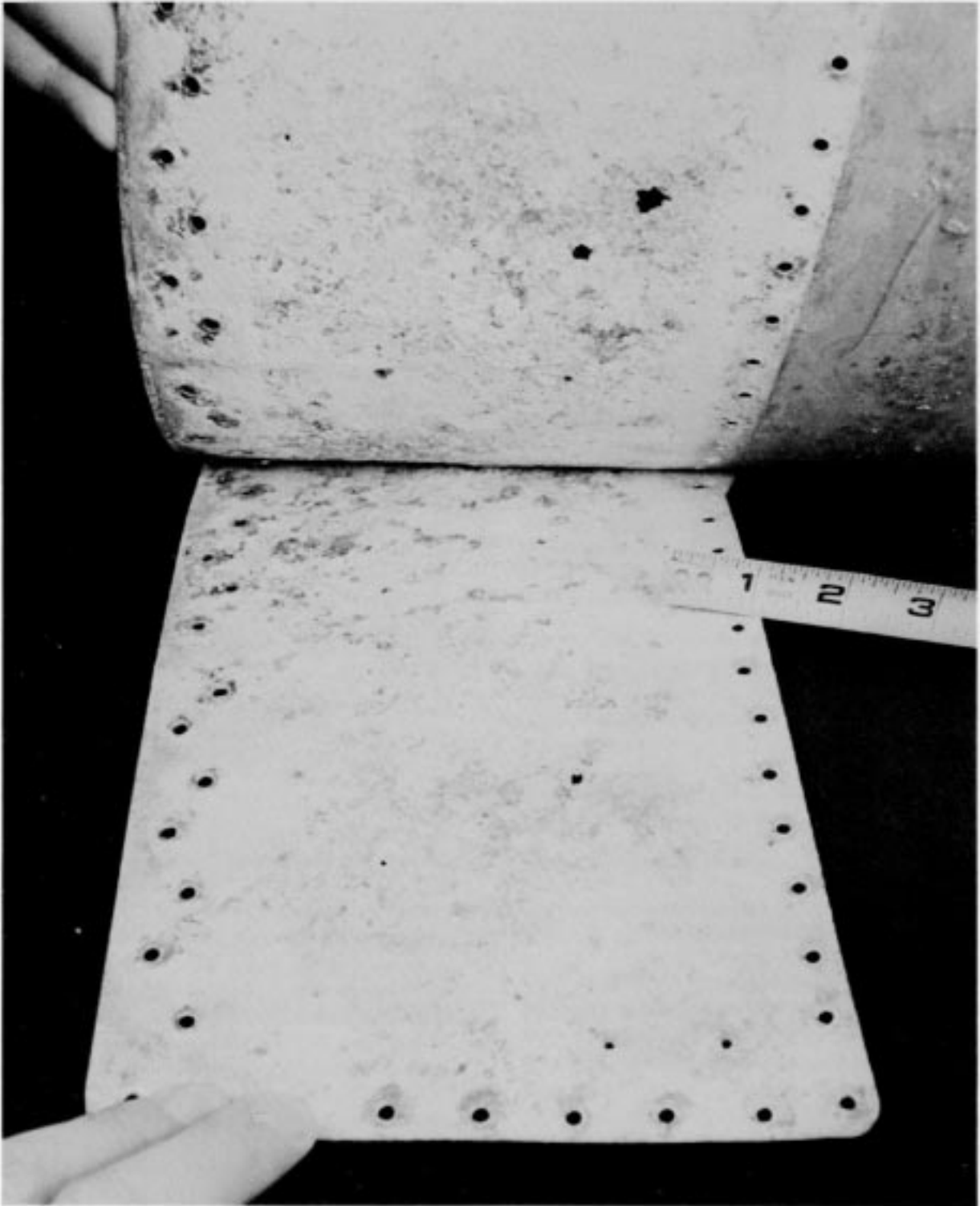

**Corrosion is ugly all the way through.**