

SERVICE NEWS



Service News

A SERVICE PUBLICATION OF
LOCKHEED-GEORGIA COMPANY
A DIVISION OF
LOCKHEED CORPORATION

Editor

Charles 1. Gale

Associate Editors

Daniel E. Jolley
James A. Loftin
Steve Palmer

Art Direction & Production

Anne G. Anderson

Vol. 9, No. 2, April-June 1982

CONTENTS

2 Focal Point

B. B. Coker, Manager
Standards Engineering Dept.

3 Lubricants for Hercules Aircraft

A helpful list of lubricants
and distributors.

11 Hydraulic Fluid Transfer



An update on hydraulic fluid
transfer between systems.

10 StarTip

Starter Oil Leak Detection

Cover: A C-130H of the Belgian Air Force over the north Georgia countryside.

Belgium's first C-130H was delivered nearly a decade ago. Twelve of these multi-purpose airlifters are now in the nation's inventory. They replaced a fleet of 40 C-119s.

Published by Lockheed-Georgia Company, a Division of Lockheed Corporation. Information contained in this issue is considered by Lockheed-Georgia Company to be accurate and authoritative; it should not be assumed, however, that this material has received approval from any governmental agency or military service unless it is specifically noted. This publication is for planning and information purposes only, and it is not to be construed as authority for making changes on aircraft or equipment, or as superseding any established operational or maintenance procedures or policies. The following marks are registered and owned by Lockheed Corporation: , , "Hercules," and "JetStar." Written permission must be obtained from Lockheed-Georgia Company before republishing any material in this periodical. Address all communications to Editor, Service News, Department 64.22, Zone 278, Lockheed-Georgia Company, Marietta, Georgia. 30063. Copyright 1982 Lockheed Corporation.

Focal Point

ENGINEERING STANDARDS:
A KEY TO QUALITY

High-technology products such as aircraft require special care during both manufacture and operation. Materials, processes, maintenance procedures, and many individual parts are standardized, and these standards are carefully described and maintained current in bulletins, specifications, handbooks, and manuals. It is important that the data in these documents be understood and adhered to in order to realize the optimum performance from the airplane.



B. B. COKER

The maintenance of controlled engineering standards is fundamentally a form of continuous quality control. One of the ways in which controlled standards operate to protect the value that is built into every Hercules aircraft is reflected in the list of lubricants featured in this issue. The list includes the names, specifications, and manufacturers' designations of many approved lubricants, together with updated information giving the names and addresses of major suppliers. Each of these products has been manufactured to an exacting specification. When properly used, each can help ensure that vital parts of your Hercules aircraft operate efficiently and deliver the maximum possible service life.

Implicit in the idea of a controlled standard is a controlled application. An item which is covered by engineering standards must be used exactly as intended if the purpose of the overall concept is to be fulfilled. It is important to remember that quick-reference aids like this list of lubricants cannot provide full information and are not intended to be used alone. That is where the authorized manuals come in. Be sure to consult the authorized maintenance manuals to determine which of these products are approved for the aircraft operated by your organization.

There are many other examples of the use of controlled standards in the manufacture and maintenance of a modern airplane. They are applied to fasteners, electrical connectors, wire and cable, tubing, sealants, fluids, structural repair - the list is almost endless. The staff of the Standards Engineering Department here at Lockheed-Georgia Company stands ready to help our customers with any questions they may have concerning standard parts or procedures. We hope you will not hesitate to contact us through the Customer Service organization whenever we can be of assistance.

Sincerely,

B. B. Coker
Manager
Standards Engineering Department

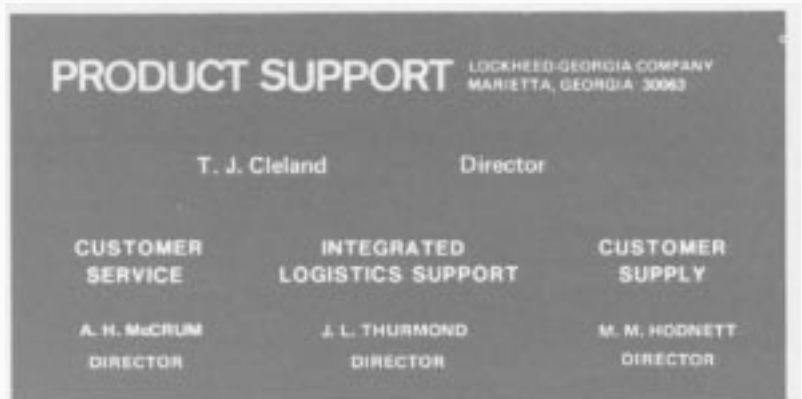

Lubricants for Hercules Aircraft

*... a helpful list of
lubricants and distributors.*

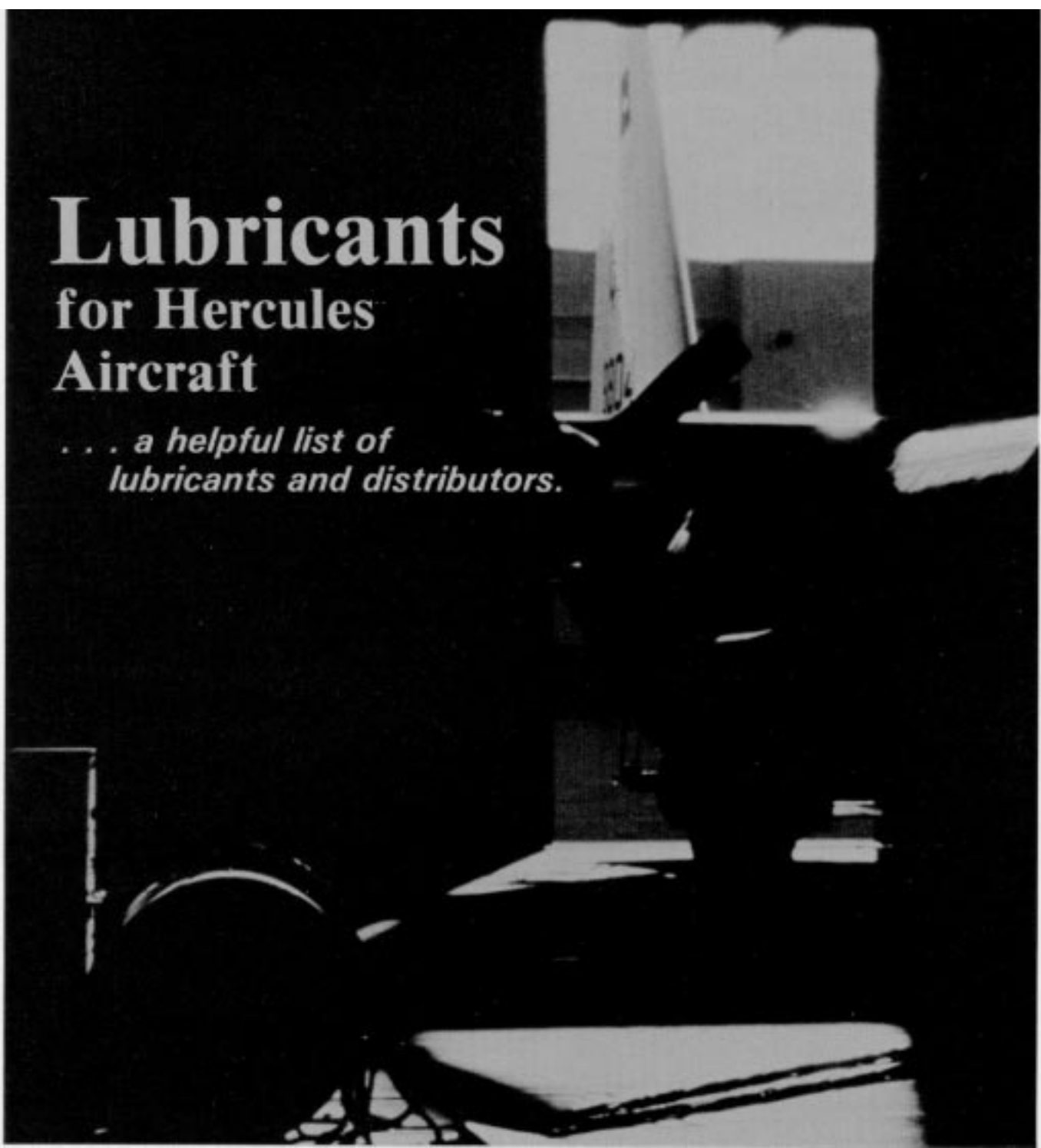

There is nothing quite so helpful as having good data at your fingertips when you need it. We hope that the material in this article will fall into that category.

The following is a list of some of the many lubricants that are used in conjunction with Hercules aircraft. Included are the names, specifications, and manufacturers' designations for the lubricants, together with updated information giving the names and addresses of a number of important suppliers. If you find that you have just about exhausted your stock of a certain lubricant, a check of this list before you order could help ensure that you will get a new supply in the shortest possible time.

Please note that the fact that a particular lubricant appears on our list does **not** necessarily mean that it is approved for use on all Hercules airplanes. Consult the authorized maintenance manuals to determine which of these substances are approved for the aircraft operated by your organization.

The reader should also be aware that in cases where a series of lubricants with the same basic designation is given in the list (for example, the PQ Turbine Lubricant series, the Royce 899 series), the distributor may be able to furnish only the most recent formulation of the product.

Note: Not all the lubricants listed are suitable for all Hercules aircraft. Consult your authorized technical manuals.

ITEM	SPECIFICATION	MANUFACTURER'S DESIGNATION	DISTRIBUTORS	ADDRESS CODE *
1. Aircraft & Instrument Grease	MIL-G-23827	1. AEROSHELL GREASE 7	Shell Oil Co.	61
		2. CASTROLEASE AI	Burmah-Castrol Inc.	14
		3. LOW TEMP GREASE EP	Texaco Inc.	70
		4. MOBILGREASE 27	Mobil Oil Corp.	43
		5. ROYCO 27A	Royal Lubricants Co. Inc.	58
		6. SOUTHWEST GREASE NO. 16215	Southwest Grease & Oil Co. Inc.	62
		7. SUPERMIL GREASE NO. A 72832	Amoco Oil Co.	4
		8. 5114 EP GREASE	Exxon Co. U.S.A.	30
2. Aircraft Turbine Engine Lubricating Oil	MIL-L-7808	1. AEROSHELL TURBINE OIL 308	Shell International Petroleum Co. Ltd.	59
		2. BP AERO TURBINE OIL 40	BP Oil Corp.	11
		3. BRAYCO 880 J	Bray Oil Co. Inc.	12
		4. CALTEX CODE #2217 SATO 35	California Texas Oil Corp.	16
		5. E-6825	Stauffer Chemical Co.	64
		6. ESSO TURBO OIL 2389	Exxon Co. U.S.A.	30
		7. EXXON TURBO OIL 2389	Exxon Co. U.S.A.	30
		8. PQ TURBINE OIL 8365	American Oil & Supply Co.	3
		9. PO TURBINE OIL 8366	American Oil & Supply Co.	3
		10. RM-201A	Mobil Oil Corp.	43
		11. RM-248A	Mobil Oil Corp.	43
		12. ROYCO 808H	Royal Lubricants Co. Inc.	58
		13. ROYCO808HS	Royal Lubricants Co. Inc.	58
		14. SINCLAIR TURBO S OIL 1048 IMPROVED	BP Oil Corp.	11
	15. TEXACO SATO 35	Texaco Inc.	69	
	16. TURBO OIL 2391	Exxon Co. U.S.A.	30	
	MIL-L-23699	1. AEROSHELL TURBINE OIL 500	Shell International Petroleum Co. Ltd.	59
		2. AEROSHELL TURBINE OIL 500	Shell of Canada Ltd.	60
		3. AEROSHELL TURBINE OIL 500	Shell Oil Co.	61
		4. AEROSHELL TURBINE OIL 515	Shell Oil Co.	61
		5. AMOCO JET II	Amoco Oil Co.	4
		6. AVREX S TURBO 260	Mobil Oil Corp.	43
		7. AVREXSTURBO 265	Mobil Oil Corp.	43
		8. BP ENERJET 51	BP Oil Corp.	11
9. BRAYCO 899		Bray Oil Co. Inc.	12	
10. BRAYCO 899D		Bray Oil Co. Inc.	12	
11. BRAYCO 899E	Bray Oil Co. Inc.	12		
12. BRAYCO 899F	Bray Oil Co. Inc.	12		
13. BRAYCO 8990	Bray Oil Co. Inc.	12		
14. BRAYCO 899H	Bray Oil Co. Inc.	12		
15. BRAYCO 899M	Bray Oil Co. Inc.	12		
16. BRAYCO 899s	Bray Oil Co. Inc.	12		
17. CALTEX RPM JET ENGINE OIL 5	California Texas Oil Corp.	16		
18. CASTROL 205	Burmah-Castrol Inc.	14		
19. CASTROL 5000	Burmah-Castrol Corp.	15		
20. CHEVRON JET ENGINE OIL 5	Chevron International Oil Co. Inc.	17		
21. CHEVRON JET ENGINE OIL 5	Standard Oil Co. of California	63		
22. EMGARD SYNTHESIZED TURBINE LUBRICANT (2952)	Emery Industries Inc.	28		
23. ESSO TURBO OIL 2380	Exxon Co. U.S.A.	30		
24. EXXON TURBO OIL 2380	Exxon Co. U.S.A.	30		

*Address Code: See the List of Distributors and Address

ITEM	SPECIFICATION	MANUFACTURER'S DESIGNATION	DISTRIBUTORS	ADDRESS CODE ■		
2. Aircraft Turbine Engine Lubricating Oil – contd.	MIL-L-23699	25. HATCOL 3211	Hatco Chemical Corp.	37		
		26. HATCOL 3611	Hatco Chemical Corp.	37		
		27. METREX TURBO OIL-1	Hexagon Enterprises Inc.	38		
		28. METREX TURBO OIL-2	Hexagon Enterprises Inc.	38		
		29. METREX TURBO OIL-3	Hexagon Enterprises Inc.	38		
		30. METREX TURBO OIL-4	Hexagon Enterprises Inc.	38		
		31. MOBIL JET OIL II	Mobil Sales & Supply Corp.	44		
		32. PQ TURBINE LUBRICANT 3889	American Oil & Supply Co.	3		
		33. PQ TURBINE LUBRICANT 3893	American Oil & Supply Co.	3		
		34. PQ TURBINE LUBRICANT 6423	American Oil & Supply Co.	3		
		35. PQ TURBINE LUBRICANT 6700	American Oil & Supply Co.	3		
		36. PQ TURBINE LUBRICANT 8878	American Oil & Supply Co.	3		
		37. PQ TURBINE LUBRICANT 9595	American Oil & Supply Co.	3		
		38. PQ TURBINE LUBRICANT 9596	American Oil & Supply Co.	3		
		39. PQ TURBINE LUBRICANT 9597	American Oil & Supply Co.	3		
		40. PQ TURBINE LUBRICANT 9598	American Oil & Supply Co.	3		
		41. PQ TURBINE LUBRICANT C-3788	American Oil & Supply Co.	3		
		42. RM-139A	Mobil Oil Corp.	43		
		43. RM-147A	Mobil Oil Corp.	43		
		44. RM-246A	Mobil Oil Corp.	43		
		45. RM-247A	Mobil Oil Corp.	43		
		46. RM-249A	Mobil Oil Corp.	43		
		47. ROYCO 899 (C-915)	Royal Lubricants Co. Inc.	58		
		48. ROYCO 899B (O-759-3)	Royal Lubricants Co. Inc.	58		
		49. ROYCO 899C (D-758)	Royal Lubricants Co. Inc.	58		
		50. ROYCO 899HC	Royal Lubricants Co. Inc.	68		
		51. ROYCO 899P-1	Royal Lubricants Co. Inc.	58		
		52. ROYCO 899P-2	Royal Lubricants Co. Inc.	58		
		53. ROYCO 899P-3	Royal Lubricants Co. Inc.	58		
		54. ROYCO 899P-4	Royal Lubricants Co. Inc.	58		
		55. SINCLAIR TURBO S OIL	Atlantic Richfield Co.	10		
		56. STAUFFER JET II (CASTROL 205)	Stauffer Chemical Co.	65		
		57. STAUFFER STL	Stauffer Chemical Co.	66		
		58. STAUFFER 6924	Stauffer Chemical Co.	66		
		59. STO-5700	PVO International Inc.	55		
		60. STO-6530	PVO International Inc.	55		
		61. STO-21919	PVO International Inc.	55		
		62. STO-21919A	PVO International Inc.	55		
		63. 2395 TURBO OIL	Exxon Co. U.S.A.	30		
		3. Anti-Seize Compound	MIL-L-25681	1. BRAYCO 868	Bray Oil Co. Inc.	12
				2. CP-63	E/M Lubricants Inc.	27
				3. MOLYKOTE 50/50	Dow Corning Corp.	22
				4. ROYCO 81 MS	Royal Lubricants Co. Inc.	58
		4. Corrosion Preventive Compound	MIL-C-16173 Grade 3	1. BRAYCOTE 153E	Bray Oil Co. Inc.	12
				2. FERROCOTE 364-BL	Quaker Chemical Corp.	56
				3. FERROCOTE 367-BL	Quaker Chemical Corp.	56
				4. NO-RUST 28	Steven Industries	67
				5. NOX-RUST 208	Nox-Rust Division, Daubert Chemical Co.	46
				6. OAKITE SPECIAL PROTECTIVE OIL Q	Oakite Products Inc.	48
				7. OMEGA 512-5	Omega Chemical Co. Inc.	51

Note: Not all the lubricants listed are suitable for all Hercules aircraft. Consult your authorized technical manuals.

ITEM	SPECIFICATION	MANUFACTURER'S DESIGNATION	DISTRIBUTORS	ADDRESS CODE *	
4. Corrosion Preventive Compound – contd.	MIL-C-16173 Grade 3	8. PETROTECT 3	Penreco	52	
		9. P3A	Steven Industries	67	
		10. ROYCO 153R	Royal Lubricants Co. Inc.	58	
		11. RUST-FOIL 16 I-3	Franklin Oil Corp. (Ohio)	31	
		12. STEELGARD MS-1 2	Herry Miller Corp.	36	
		13. ST 1894	Steven Industries	67	
		14. VALVOLINE TECTYL 894	Ashland Petroleum Co.	9	
		15. VEEDOL ANORUSTOL 270	Deutsche Veedol GmbH	21	
		16. VISCORUST NO. 1603	Viscosity Oil Co.	72	
		17. WESTERN OMEGA 512-5	Omega Chemical Co. Inc.	51	
		18. 894-BC	Bulk Chemicals Distributors Inc.	13	
		MIL-C-16173 Grade 4	1. BRAYCOTE 194	Bray Oil Co. Inc.	12
			2. BRAYCOTE 194E	Bray Oil Co. Inc.	12
			3. COSMOLINE 1112	E. F. Houghton & Co.	25
			4. NO-RUST X-I 0	Steven Industries	67
			5. NOX-RUST X-I 10	Nox-Rust Division, Daubert Chemical Co.	46
			6. PETROTECT AMBER	Penreco	52
			7. POLY OLEUM 5000	Poly Oleum Corp.	54
	8. P4A		Steven Industries	67	
	9. ROYCO 194R		Royal Lubricants Co. Inc.	58	
	10. RUST-BAN 397		Esso A.G.	29	
	11. RUST-FOIL 16 1-4		Franklin Oil Corp. (Ohio)	31	
	12. ST 1846		Steven Industries	67	
	13. VALVOLINE TECTYL 848		Ashland Petroleum Co.	9	
	14. VEEDOL ANORUSTOL 275		Deutsche Veedol GmbH	21	
	15. 846.BC		Bulk Chemicals Distributors Inc.	13	
	5. Fluorocarbon Lubricant	MIL-L-60326	1. MS-I 22	Miller-Stephenson Chemical Co. Inc.	42
			2. MS-143	Miller-Stephenson Chemical Co. Inc.	42
3. TIOLON A20			Tiodize Co. Inc.	71	
6. General Purpose Grease (Wide Temperature Range)	MIL-G-8 1322	1. AEROSHELL GREASE 22	Shell Oil Co.	61	
		2. AEROSHELL GREASE 22c	Shell International Petroleum Co. Ltd.	59	
		3. MOBILGREASE 28	Mobil Oil Corp.	43	
		4. ROYCO NO. 22C	Royal Lubricants Co. Inc.	58	
7. General Purpose Lubricating Oil (Low Temperature)	MIL-L-7870	1. BRAYCO 363	Bray Oil Co. Inc.	12	
		2. COSMOLUBRIC NO. 263	E. F. Houghton & Co.	24	
		3. GULFLITE OIL 6	Gulf Oil Corp.	33	
		4. NOX-RUST 529	Nox-Rust Division Daubert Chemical Co.	46	
		5. OCTOIL 70	Octagon Process Inc.	49	
		6. PETROTECT 7870A	Penreco	52	
		7. "PQ" RUST PREVENTIVE NO. 107	American Oil & Supply Co.	3	
		8. ROYCO 363	Shell International Petroleum Co. Ltd.	59	
		9. TURBONYCOIL 160	NYCO S.A.	47	
		10. WINSOR LUBE L-101 8	Anderson Oil & Chemical Co. Inc.	5	
		11. 1692 LOW TEMP OIL	Texaco Inc.	70	
8. Hydraulic Fluid /Petroleum Base)	MIL-H-5606	1. AEROSHELL FLUID 41	Shell International Petroleum Co. Ltd.	59	
		2. BRAYCO 756C	Bray Oil Co. Inc.	12	
		3. BRAYCO756D	Bray Oil Co. Inc.	12	
		4. BRAYCO 756E	Bray Oil Co. Inc.	12	

ITEM	SPECIFICATION	MANUFACTURER'S DESIGNATION	DISTRIBUTORS	ADDRESS CODE *		
8. Hydraulic Fluid (Petroleum Base) – contd.	MIL-H-5606	5. BRAYCO 756F	Bray Oil Co. Inc.	12		
		6. BRAYCO 7578	Bray Oil Co. Inc.	12		
		7. BRAYCO MICRONIC 756ES	Bray Oil Co. Inc.	12		
		8. CASTROL HYPIN A	Burmah-Castrol Inc.	14		
		9. CHEVRON AVIATION HYDRAULIC FLUID D	Chevron U.S.A. Inc.	18		
		10. DS-437	Royal Lubricants Co. Inc.	58		
		11. MOBIL AERO HFD	Mobil Oil Corp.	43		
		12. PED 3337	Standard Oil Co. of California	63		
		13. PED 3565	Standard Oil Co. of California	63		
		14. PETROFLUID 4606	Penreco	52		
		15. PETROFLUID 4607	Penreco	52		
		16. PQ 2883	American Oil & Supply Co.	3		
		17. PQ 2890	American Oil & Supply Co.	3		
		18. ROYCO 756C	Royal Lubricants Co. Inc.	58		
		19. ROYCO 756D	Royal Lubricants Co. Inc.	58		
		20. STAUFFER AERO HYDROIL 500	Stauffer Chemical Co.	65		
		21. TL 5874	Texaco Inc.	70		
		22. 25606	MZF Associates	45		
		9. Hydraulic Fluid (Petroleum Base – for Preservation & Testing)	MIL-H-6083	1. AVREX 904	Mobil Oil Corp.	43
				2. BRAYCO783C	Bray Oil Co. Inc.	12
				3. BRAYCO 783E	Bray Oil Co. Inc.	12
				4. HYPIN P	Burmah-Castro ¹ Inc.	14
5. PETROTECT 4066C	Penreco			52		
6. ROYCO 783C	Royal Lubricants Co. Inc.			58		
7. UNIVIS PJ-42	Exxon Co. U.S.A.			30		
10. Hydraulic Fluid (Synthetic Hydrocarbon Base – Fire Resistant)	MIL-H-83282	1. AEROSHELL FLUID 31	Shell International Petroleum Co. Ltd.	59		
		2. BRAYCO MICRONIC 882	Bray Oil Co. Inc.	12		
		3. HANOVER R-2	Hanover Processing Co.	35		
		4. HF-832	Hanover Processing Co.	35		
		5. HYDRAUNYCOIL FH2	NYCO S.A.	47		
		8. PETROFLUID 822	Penreco	52		
		7. PQ 3883	American Oil & Supply Co.	3		
		8. ROYCO 782	Royal Lubricants Co. Inc.	58		
		9. TS-741	Gulf Oil Chemicals Co.	32		
		11. Instrument Lubricating Oil (Low Volatility)	MIL-L-6085	1. ANDEROL L-40 1 -D	Tenneco Chemicals	68
2. BRAYCO 885	Bray Oil Co. Inc.			12		
3. COSMOLUBRIC NO. 270-A	E. F. Houghton & Co.			24		
4. KC-85A	Tenneco Chemicals			68		
5. L-245X	Anderson Oil & Chemical Co. Inc.			5		
6. "PQ" RUST PREVENTIVE NO. 160	American Oil & Supply Co.			3		
7. PRODUCT 80	Octagon Process Inc.			49		
8. UNIVIS P-I 2	Exxon Co. U.S.A.			30		
9. VISCORUST 1615	Viscosity Oil Co.			72		
12. Lubricating Oil (Preservative) VV-L-800		1. AERO LUBE "A"	Aerosol Systems Inc.	1		
		2. ALOX 2199A	Alox Corp.	2		
		3. BRAYCO 300	Bray Oil Co. Inc.	12		
		4. CLARCO WDL	Clarkson Laboratories Inc.	19		
		5. CLING SURFACE G-I 9722	Cling Surface Co.	20		
		6. COSMOLINE 1116	E. F. Houghton & Co.	24		
		7. DRYDENE PRESERVATIVE OIL #1206	Dryden Oil Co. Inc.	23		
		8. FORMULA GPLO	John Swift Chemical Co. Inc.	39		
		9. HC-433	Hanover Chemical Industries Inc.	34		

Note: Not all the lubricants listed are suitable for all Hercules aircraft. Consult your authorized technical manuals.

ITEM	SPECIFICATION	MANUFACTURER'S DESIGNATION	DISTRIBUTORS	ADDRESS CODE *
12. Lubricating Oil (Preservative) VV-L-800 - contd.		10. NOX-RUST 518	Nox-Rust Division, Daubert Chemical Co.	46
		11. OCTOIL 90	octagon Process Inc.	49
		12. PETROTECT 800	Penreco	52
		13. PETROTECT 4072C	Penreco	52
		14. PHOSPHOTEX 4981	MacDermid Inc.	40
		15. PQ RUST PREVENTIVE NO. 172	American Oil & Supply Co.	3
		16. ROYCO 308A	Royal Lubricants Co. Inc.	58
		17. RUST FOIL #2675	Franklin Oil Corp. (Ohio)	31
		18. TECTYL 893	Ashland Oil Inc.	8
		19. TECTYL 900	Ashland Oil Inc.	8
		20. WITHROGARD RP97	Arthur C. Withrow Co.	7
		21. WITHROGARD 761	Arthur C. Withrow Co.	7
		22. ZURNKOTE 008	O. F. Zurn Co.	50
23. 900 - BC	Malter International Corp.	41		
13. Molybdenum Disulfide Grease (Low & High Temperatures)	MIL-G-21164	1. AEROSHELL GREASE 17	Shall Oil Co.	61
		2. CASTROLEASE MSA (C)	Burmah-Castrol Inc.	14
		3. EVERLUBE 211 -G MOLY GREASE	E/M Lubricants Inc.	27
		4. ROYCO 64C	Royal Lubricants Co. Inc.	58
14. Molybdenum Disulfide Powder	MIL-M-7866	1. BRAYCO 866	Bray Oil Co. Inc.	12
		2. ELECTRO-MOLY GRADE 2	Electrofilm Inc.	26
		3. MOLYKOTE Z	Dow Corning Corp.	22
		4. ROYCO 66MS	Royal Lubricants Co. Inc.	58
15. Penetrating Oil	VV-P-216	1. LIQUID WRENCH	Radiator Specialty Co.	57
16. Petrolatum (Anti-Seize Thread Compound)	MIL-T-83483	1. MOLY-PETROLATUM	Armite Laboratories	6
17. Silicone Lubricant (Spray)	NSN 9150-00-823. 7860	1. SLYDE	Bulk Chemicals Distributors Inc	13
18. Solid Film Lubricant (Air Cured - Corrosion Inhibiting)	MIL-L-46 147	1. LUBRI-BOND 220	Electrofilm Inc.	26
		2. MOLYKOTE 3402 BONDED LUBRICANT	Dow Corning Corp.	22

DISTRIBUTORS and ADDRESSES

Address Code	Address	Address Code	Address	Address Code	Address
1	Aerosol Systems Inc. 9150 Valley View Rd. Macedonia, OH 44056	7	Arthur C. Withrow Co. 55 1 1 District Blvd. Los Angeles, CA 90040	13	Bulk Chemicals Distributors Inc. Div. of Malter International Corp. 80 First St. Gretna, LA 70053
2	Alox Corp. P.O. Box 517 Niagara Falls, NY 14302	8	Ashland Oil Inc. 1409 Winchester Ave. Ashland, KY 41101	14	Burmah-Castrol Inc. Continental Plaza 401 Hackensack Ave. Hackensack, NJ 07601
3	American Oil & Supply CO. 238 Wilson Ave. Newark, NJ 07105	9	Ashland Petroleum Co. Div. of Ashland Oil Inc. P.O. Box 391 Ashland, KY 41101	15	Burmah-Castrol Corp. Burmah House Pipers Way Swindon Wilts SN3 1RE England
4	Amoco Oil Co. 200 E. Randolph Dr. Chicago, IL 60601	10	Atlantic Richfield Co. 875 N. Michigan Ave. Chicago, IL 6061 1	16	California Texas Oil Corp. 380 Madison Ave. New York, NY 10017
5	Anderson Oil & Chemical Co. Inc P.O. Box 111 Portland, CT 06480	11	BP Oil Corp. Midland Bldg. Cleveland, OH 44115	17	Chevron International Oil Co. Inc. 555 Market St. San Francisco, CA 94105
6	Armite Laboratories 1845 Randolph St. Los Angeles, CA 90001	12	Bray Oil Co. Inc. 1925 N. Marianna Ave. Los Angeles, CA 90032		

DISTRIBUTORS and ADDRESSES

Address Code	Address	Address Code	Address	Address Code	Address
18	Chevron U.S.A. Inc. 575 Market St. San Francisco, CA 94105	33	Gulf Oil Corp. Gulf Bldg. Pittsburgh, PA 15219	48	Oakite Products Inc. 50 Valley Rd. Berkeley Heights, NJ 07922
19	Clarkson Laboratories Inc. 1450 Ferry Ave. Camden, NJ 08104	34	Hanover Chemical Industries Inc. Little Rd. P.O. Box 147 East Hanover, NJ 07936	49	octagon Process Inc. 596 River Rd. Edgewater, NJ 07020
20	Cling Surface Co. 1048 Niagara St. Buffalo, NY 14213	35	Hanover Processing Corp. P.O. Box 302 East Hanover, NJ 07936	50	O.F. Zurn Co. 2736 N. Broad St. Philadelphia, PA 19132
21	Deutsche Veedol GmbH Hauptabteilung Grossverbraucher Esplanade 39 2000 Hamburg 36 West Germany	36	Harry Miller Corp. 4th & Bristol Sts. Philadelphia, PA 19 140	51	Omega Chemical Co. Inc. 6935 W. 62nd St. Chicago, IL 60638
22	Dow Corning Corp. P.O. Box 1767 Midland, MI 48640	37	Hatco Chemical Corp. King George Post Rd. Fords, NJ 08863	52	Penreco P.O. Box 671 Butler, PA 16001
23	Dryden Oil Co. Inc. Braddish Ave. & W.M.R.R. Baltimore, MD 2 1216	38	Hexagon Enterprises Inc. 36 Midvale Rd. Mountain Lakes, NJ 07046	53	Penreco Karns City, PA 1604 1
24	E.F. Houghton & Co. 303 W. Lehigh Ave. Philadelphia, PA 19133	39	John Swift Chemical Co. Inc. P.O. Box 307 Albany Turnpike Canton, CT 06019	54	Poly Oleum Corp. 13531 Greenfield Rd. Detroit, MI 48227
25	E.F. Houghton & Co. Madison & Van Buren Aves. Valley Forge, PA 19482	40	MacDermid Inc. 1221 Farrow St. Ferndale. MI 48220	55	PVO International Inc. Chemical Specialties Div. Customer Service Park P.O. Box 2167 Morristown, NJ 07960
26	Electrofilm Inc. Lubricants Div. P. O. Box 3930 7 116 Laurel Canyon Blvd. North Hollywood. CA 916C5	41	Malter International Corp. P. O. Box 6099 New Orleans. LA 70174	56	Quaker Chemical Corp. Elm & Lime Sts. Conshohocken, PA 19428
27	E/M Lubricants Inc. P.O. Box 2200 West Lafayette, IN 47906	42	Miller-Stephenson Chemical Co. Inc George Washington Hwy. Danbury, CT 06810	57	Radiator Specialty Co. 1400 W. Independence Blvd. Charlotte, NC 28208
28	Emery Industries Inc. 1300 Carew Tower Cincinnati, OH 45202	43	Mobil Oil Corp. 150 E. 42nd St. New York, NY 100 17	58	Royal Lubricants Co. Inc. River Rd. East Hanover, NJ 07936
29	Esso A.G. Kapstadtring 2 2000 Hamburg 60 West Germany	44	Mobil Sales & Supply Corp. 150 E. 42nd St. New York, NY 10017	59	Shell International Petroleum Co. Ltd. Shell Centre London SE1 7NA England
30	Exxon Co. U.S.A. P.O. Box 2180 Houston. TX 77001	45	MZF Associates 11200 Homedale St. Los Angeles, CA 90049	60	Shell of Canada Ltd. Aviation Sales P.O. Box 400, Term. "A" Toronto M5W 1 E1 Ontario Canada
31	Franklin Oil Corp. [Ohio] 40 S. Park St. Bedford. OH 44146	46	Nox-Rust Division Daubert Chemical Co. 4700 S. Central Ave. Chicago, IL 60638	61	Shell Oil Co. One Shell Plaza P.O. Box 2463 Houston. TX 77001
32	Gulf Oil Chemicals Co. P.O. Box 3766 Houston, TX 77001	47	NYCO S.A. 66 Avenue des Champs-Elysees 51 Rue de Ponthieu 75008 Paris France	62	Southwest Grease & Oil Co. Inc. P.O. Box 1974 1400 S. Harrison Olathe. KS 66061

DISTRIBUTORS and ADDRESSES

Address Code		Address Code		Address Code	
63	Standard Oil Co. of California 225 Bush St. San Francisco, CA 94104	67	Steven Industries P.O. Box 8 39 Avenue C Bayonne, NJ 07002	71	Tiodize Co. Inc. 15701 Industry Lane Huntington Beach, CA 92649
64	Stauffer Chemical Co. Specialty Chemical Div. Nyala Farm Rd. Westport. CT 06880	68	Tenneco Chemicals Turner Place P.O. Box 2 Piscataway, NJ 08854	72	Viscosity Oil Co. 3202 S. Western Ave. Chicago, IL 60608
65	Stauffer Chemical Co. 380 Madison Ave. New York, NY 10017	69	Texaco Inc. 135 E. 42nd St. New York, NY 10017		
66	Stauffer Chemical Co. 299 Park Ave. New York, NY 10171	70	Texaco Inc. Petroleum Products Dept P. O. Box 52332 Houston, TX 77052		

SERVICE NEWS

StarTip

STARTER OIL LEAK DETECTION

Some engine starters used on Hercules aircraft, such as the AiResearch model ATSI OO-422, contain an internal supply of lubricating oil. If a minor oil leak is discovered in the vicinity of a starter mounting pad when starters of this type are being used, it may be difficult to determine whether the oil is leaking from inside the reduction gearbox or from the starter unit.

There is a simple procedure that can help pinpoint the source of the leak in such cases, and it is approved for use with AiResearch starters. The basic idea is to put a little dye in the starter oil and then check to see if the dyed oil shows up where it is not supposed to be. The details have been kindly provided to us by the Garrett Corporation.

Here is how to proceed: Obtain a small quantity of Automate Blue #8 dye (available from Morton-Norwich Products, Inc., Morton Chemical Division, 2 North Riverside Plaza, Chicago, IL 60606). This dye may be added directly to the oil in the starter that is suspected of leaking. Use one drop for 425 cc's of starter lubricant, which is the normal capacity of many starters in this series. The subsequent appearance of dyed oil indicates a starter leak. Used in the concentration described, Automate Blue #8 will impart a medium green color to the oil.

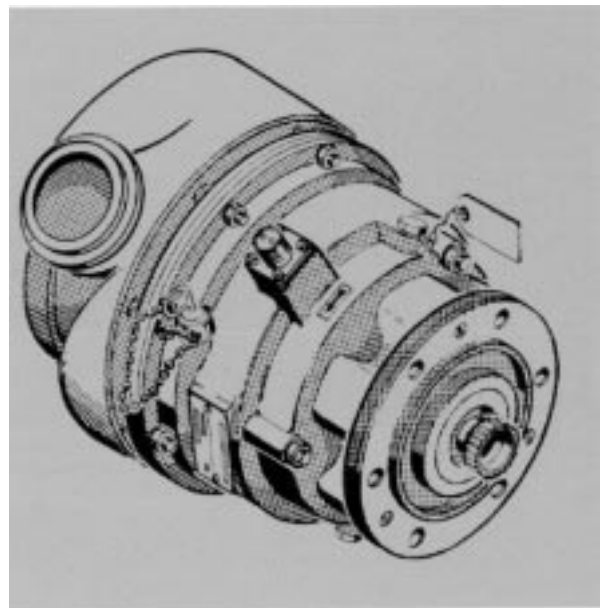

If the starter turns out to be sound, there is no need to remove the dyed oil until there is some other reason for changing it. Note, however, that while most oil-soluble dyes can be removed from steel surfaces with standard engine cleaners and solvents, any anodized aluminum that they come in contact with may be permanently stained.

Hydraulic Fluid Transfer

by John Walters, Staff Engineer

Hercules aircraft operators occasionally encounter situations in which hydraulic fluid is found to be transferring from the auxiliary to the utility hydraulic system or vice versa. When the cause is not immediately obvious — and often it is not — a lengthy and often frustrating troubleshooting effort is sometimes undertaken in which first one and then another component falls under suspicion, but no definite evidence of a malfunction is discovered.

Fortunately, there are more straightforward approaches that will usually yield satisfactory explanations for most instances of hydraulic fluid transfer. The results from investigations of a number of reported cases of hydraulic fluid transfer have made it possible to identify the most common causes of this condition with a good degree of precision. Quite often, no special maintenance action is required to correct the condition, and minor changes in operational practices are all that is necessary to prevent recurrence.

Two of the more important ways in which hydraulic fluid transfer can occur have been addressed in previous issues of Service News. The article “Hercules Hydraulic System Interconnect Valve Positioning Procedure,” which appeared in Volume 2, Number 4 (October - December 1975), emphasizes the importance of using the correct procedures when positioning the ground test checkout valve. Failure to completely deplete the pressure in the normal and emergency brake accumulators before repositioning the ground test checkout valve remains a common cause of hydraulic fluid transfer between systems. Leaking accumulator piston seals can do it too, and the effects of this problem are discussed in Volume 3, Number 3 (July - September 1976).

Several other ways in which hydraulic fluid can transfer from one system to another have come to light more recently. All have to do with operational practices rather than component failure, and any of them can produce the kind of intermittent yet persistent fluid transfer that seems specially designed to put the maintenance specialist's

skills and patience to the test. With the help of the accompanying illustrations, let us see how these situations can arise.

Repositioning the Brake Select Switch with Brakes Applied

Hydraulic fluid is sometimes inadvertently transferred from one system to the other when the brake system is switched from the normal to the emergency mode while the brakes are applied.

Figure 1 shows a simplified schematic of a Hercules aircraft brake system with the brake select switch in the NORMAL position, the brake pedals not depressed, and the parking brake off.

Note in Figure 1 that with normal brakes selected, the emergency brake selector valve is energized to a position which prevents auxiliary pump output from reaching the brakes even if the brake pedals are depressed. With normal brakes selected, the normal brake selector valve is deenergized to the position shown, which allows utility system pressure from the engine-driven pumps to reach the brakes as soon as the brake pedals are depressed.

Figure 1.

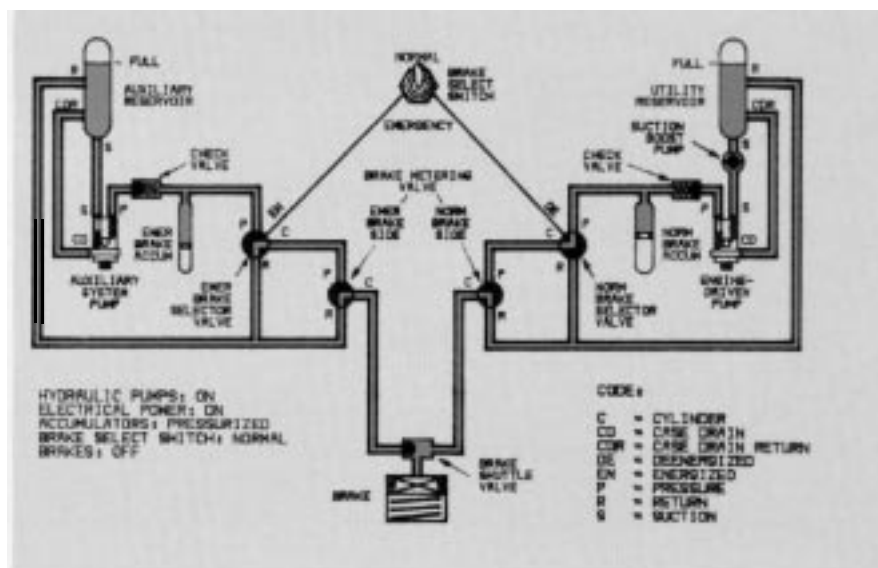

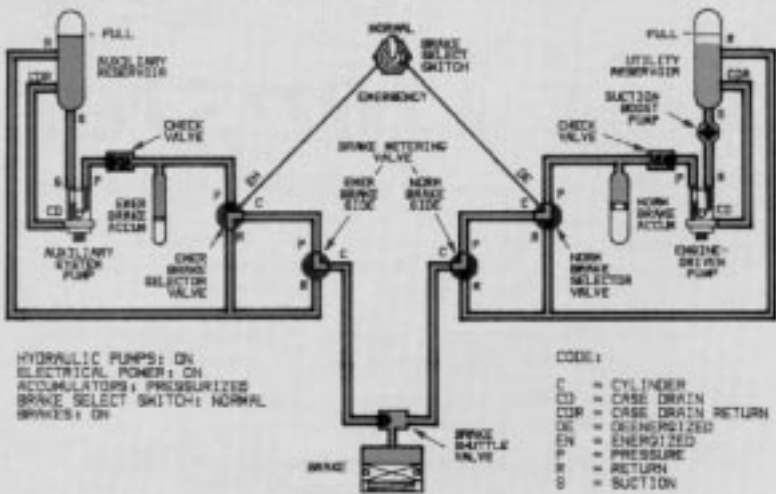

In Figure 2, the brake pedals have been depressed, which repositions both the normal and emergency brake metering valves as shown. Since the normal brake selector valve is positioned to allow pressurized fluid from the engine-driven pumps to reach the normal side of the brake metering valve, pressure is supplied to the brakes through the brake shuttle valve. Note that auxiliary system pump pressure cannot reach the shuttle valve even though the emergency side of the brake metering valve has also been repositioned.

If, however, the brake select switch is placed to EMERGENCY with the brake pedals still depressed, as shown in Figure 3, pressure now reaches the shuttle valve from the auxiliary pump because the brake selector valves have been repositioned. When the brake pedals are released, the brake metering valves return to the position shown in Figure 4. The utility system fluid that was in the brake has now passed to the auxiliary system, overfilling the reservoir.

The operation just described will result in the transfer of approximately 16 cubic inches of fluid from the utility to the auxiliary system. This will appear as an approximately one-half inch change in fluid level at the utility and auxiliary system reservoir sight gages. The transfer of fluid can also proceed from the auxiliary to the utility system by reversing the sequence of events.

Leaving Parking Brakes Applied with Electrical Power Removed

Another way in which fluid transfer can occur is related to the parking brakes and removal of electrical power from the airplane. The sequence of events which causes the problem is as follows: the parking brakes are applied with the brake select switch in EMERGENCY and then electrical power is removed from the aircraft. This can cause a fluid transfer from the auxiliary system to the utility system. Figures 5 through 9 will illustrate the condition.

In Figure 5, the brake select switch has been placed to EMERGENCY, which deenergizes the emergency brake selector valve and energizes the normal brake selector valve to the positions shown. With the auxiliary pump on, hydraulic pressure is now available at the emergency brake metering valve for brake application. Note that both the normal and emergency brake accumulators are pressurized.

In Figure 6, the brake pedals have been depressed and the parking brake set. Depressing the pedals

Figure 2.

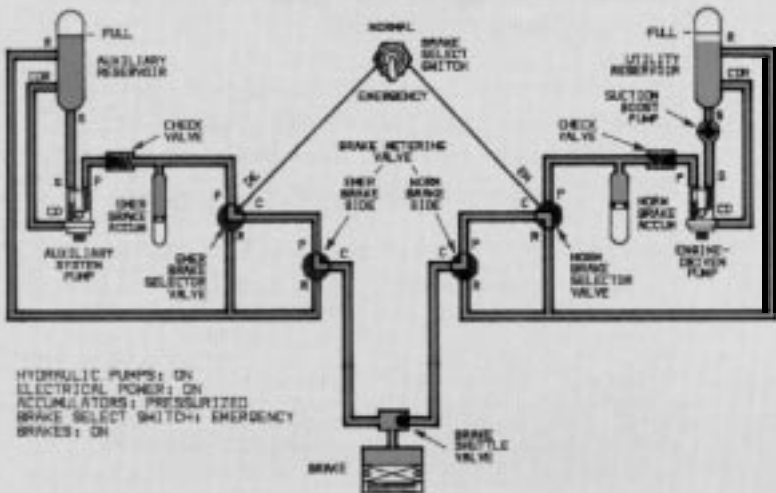
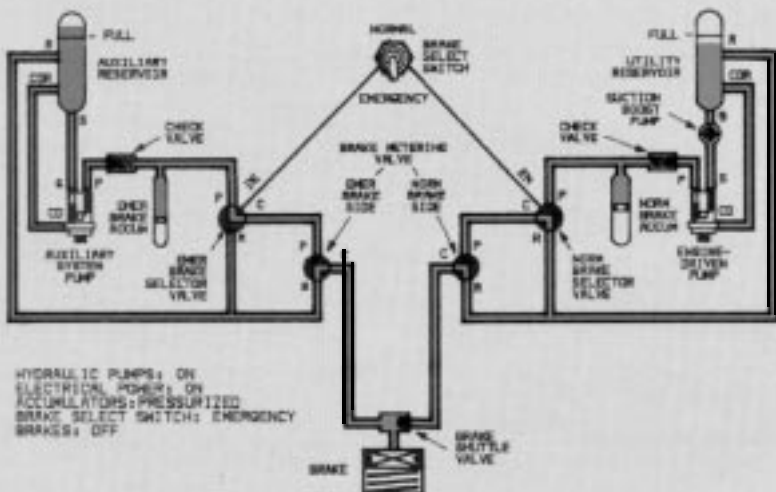

Figure 3. ▲

Figure 4. ▼



has repositioned the metering valves and allowed auxiliary system pressure to reach the brakes through the shuttle valve.

In Figure 7, electrical power has been removed from the airplane, causing the normal brake selector valve to deenergize to the position shown. With power off the airplane, neither the auxiliary pump nor the utility system engine-driven pumps are operating. Therefore, the parking brakes are being held on by the auxiliary hydraulic system fluid pressurized by the emergency brake accumulator. Note that the normal brake accumulator also supplies pressurized fluid to the shuttle valve, but since the pressures supplied by both accumulators are equal, the shuttle valve does not shift.

The fluid transfer comes about because both the normal and emergency brake systems contain valves which are allowed to leak at some specified rate. The pressure in both accumulators will therefore gradually deplete over a period of time. Assuming that both the normal and emergency systems leak at approximately the same rate, the pressure in the emergency brake accumulator will usually be expended before the pressure in the normal brake accumulator because of the larger capacity of the normal brake accumulator. At the start of leakdown, the normal brake accumulator has a capacity of 50 cubic inches of fluid, while the emergency brake accumulator has only 34 cubic inches.

In Figure 8, the emergency brake accumulator has expended all its fluid and pressure through leakage, while the normal brake accumulator has not because of its greater volume. Since the normal brake accumulator still has fluid under pressure, it causes the shuttle valve to shift. Now the parking brakes are being held on by the pressure from the normal brake accumulator.

As soon as the normal brake accumulator fluid and pressure is depleted, as shown in Figure 9, the brake puck springs return the brakes to the relaxed position, which allows the fluid originally in the auxiliary system to pass to the utility system. Transfer has occurred.

Pumping the Brake Pedals with Electrical Power Removed

Finally, fluid transfer between the auxiliary and utility systems sometimes is the product of action by the flight crew and subsequent action by maintenance personnel. The flight crew normally releases the brakes when the wheels are chocked at the end of a mission. Figure 1 (page 11) represents

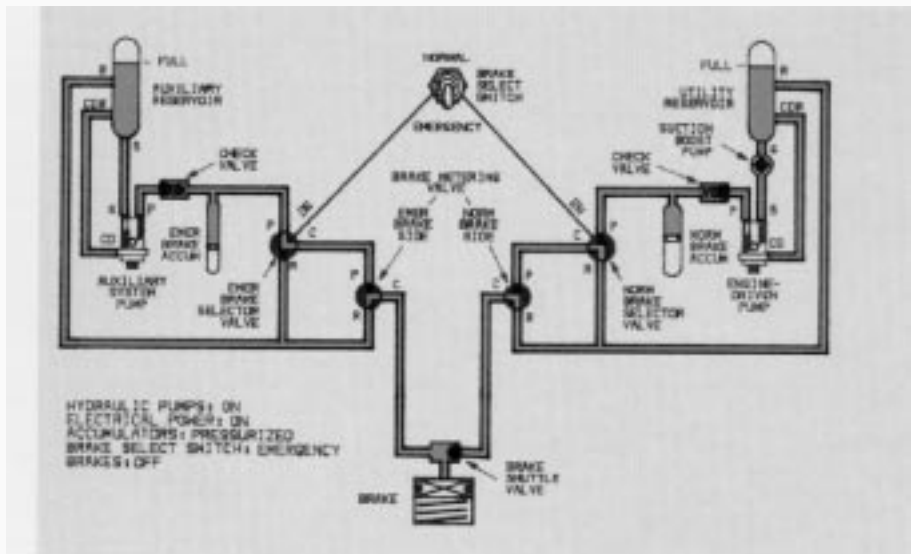

Figure 5.

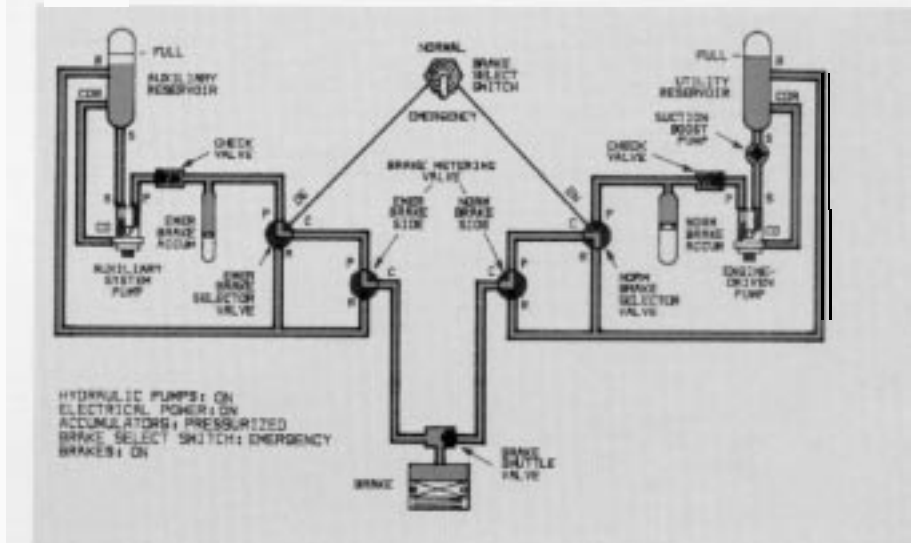
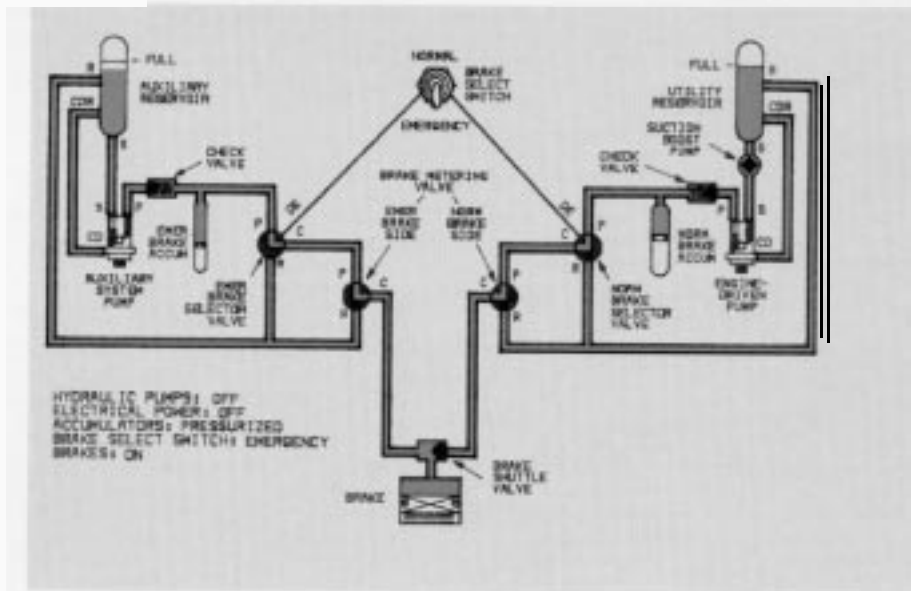

Figure 6. ▲

Figure 7. ▼



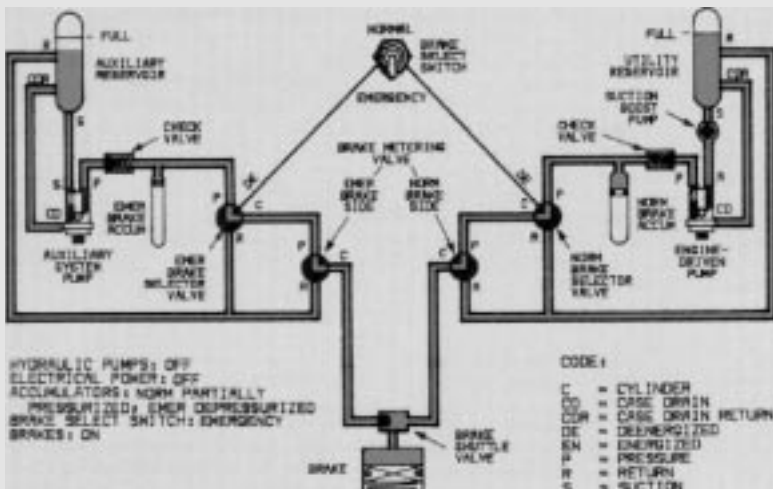

Figure 8.

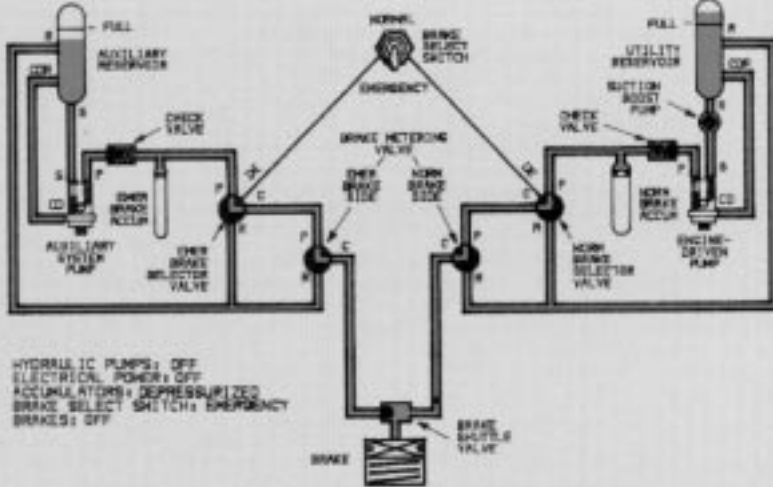
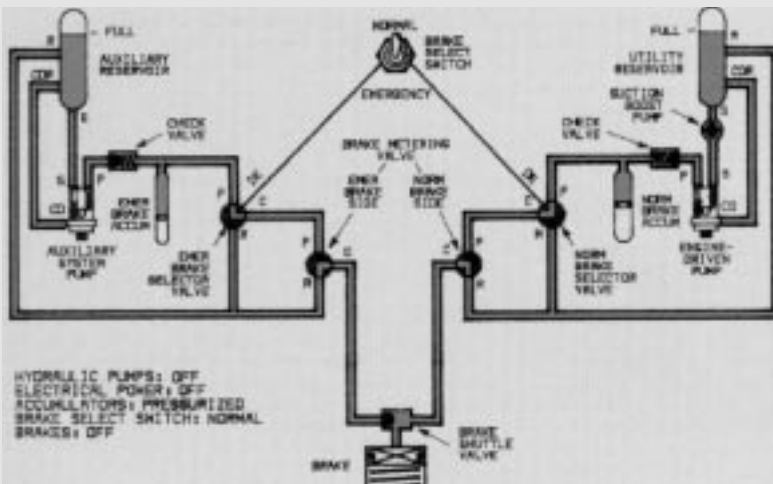

Figure 9. ▲

Figure 10. ▼



the configuration of the brake hydraulic systems after the wheels are chocked with electrical power still on, i.e. brakes released, brake select switch in NORMAL, normal and emergency brake accumulators pressurized, and selector and metering valves in the position shown. Before leaving the airplane, the flight crew shuts off electrical power, which deenergizes the emergency brake selector valve (Figure 10). Notice that with electrical power removed from the airplane, both the brake selector valves are deenergized to the position which allows the accumulators to pressurize the lines down to the brake metering valves.

The events which can lead to fluid transfer occur after the brake system has been placed in this configuration and the maintenance crew comes to the airplane. If a maintenance action requires that the brake pedals be pumped in order to bleed down both the normal and emergency brake accumulators (to reposition the ground test check-out valve, for example), and electrical power has not been restored to the airplane, fluid transfer is likely to occur. This can be visualized by looking at Figure 11, which shows the configuration of the brake hydraulic system when the brake pedals are depressed with power removed from the airplane.

Notice that both accumulators are still charged (they will, of course, bleed down over an extended period of time). Also notice that there is a straight path from both accumulators to the brake shuttle valve when the brake pedals are depressed. Initially, the shuttle valve will be as it was when the flight crew left the airplane. As the brake pedals are depressed to bleed down the accumulators, the shuttle valve will move to allow the hydraulic system with the higher pressure to apply the brakes. The action of applying the brakes causes the pressure in the higher-pressure system to decrease. A point will finally be reached where the pressure in that system decreases enough so that the alternative system becomes the higher-pressure system and shifts the shuttle valve. If the shuttle valve happens to shift when the brakes are applied, fluid from one system will be transferred to the other.

As an example, let us assume that the configuration of the brake hydraulic system is as shown in Figure 11. Let us also assume that the pressure in both accumulators is equivalent. As soon as the brake pedals are depressed, the brakes are applied by pressurized fluid from the normal brake accumulator. This decreases the pressure in the utility hydraulic system, which makes the auxiliary hydraulic system the higher-pressure system. If the

shuttle valve shifts while the brake pedals are still depressed (Figure 12), the fluid from the utility system will be passed to the auxiliary system as soon as the brake pedals are released (Figure 13). This transfer of fluid could conceivably go on until both accumulators are flat. It is not possible to predict which hydraulic system is supplying pressurized fluid to apply the brakes at any particular point in time, or to which system the fluid is going to be passed; but some net transfer will probably occur.

The following tips are offered as an aid to maintenance specialists and flight crews to prevent fluid transfer between systems:

Maintenance personnel should always be sure that the auxiliary and utility hydraulic systems are flat (zero pressure on all gages except accumulator air charge) prior to shifting the ground test checkout valve handle.

Flight crews and maintenance personnel should ensure that the brakes are off prior to switching from normal to emergency brakes, or vice versa.

Because of the allowable leakage rates of the normal and emergency brake system components, flight crews and maintenance personnel should not leave the parking brakes applied for an extended period of time with electrical power off. This should not be a problem, however, since the standard handbook procedures state to chock the wheels and release the parking brake when an airplane is to remain parked for any length of time.

Flight crews and maintenance personnel should not pump the brakes to depressurize the normal and emergency brake accumulators unless electrical power is on the aircraft. With power on the airplane, only one accumulator at a time can be bled down, which precludes the possibility of fluid transfer.

If these tips are followed, many troublesome fluid transfer problems will be eliminated along with the troubleshooting headaches that accompany them.

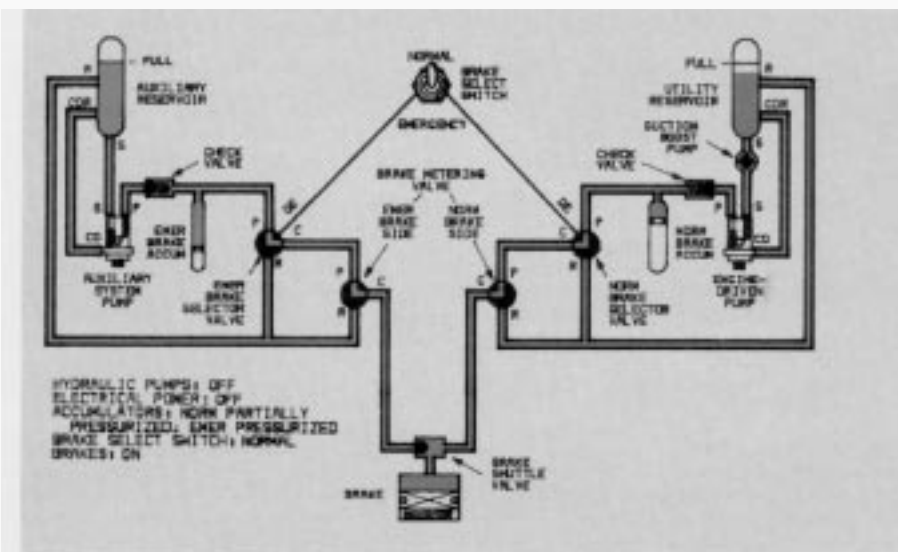

Figure 11.

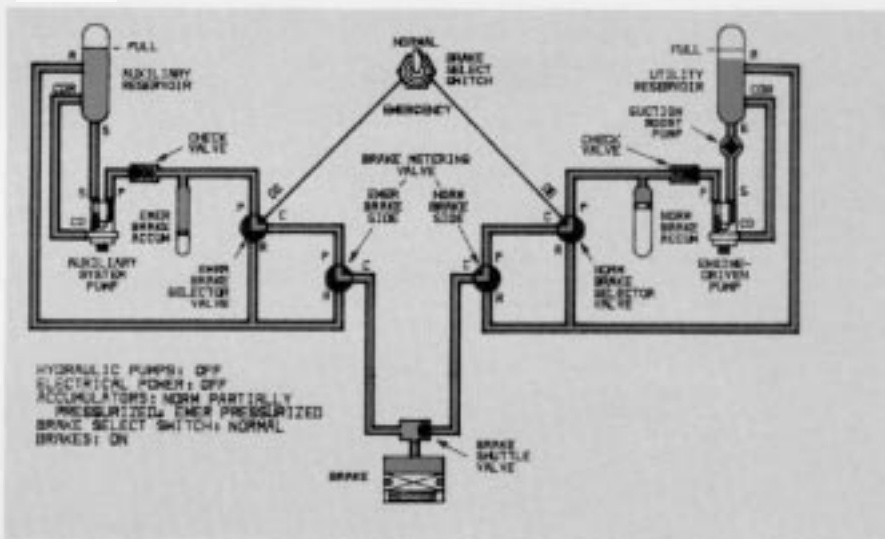
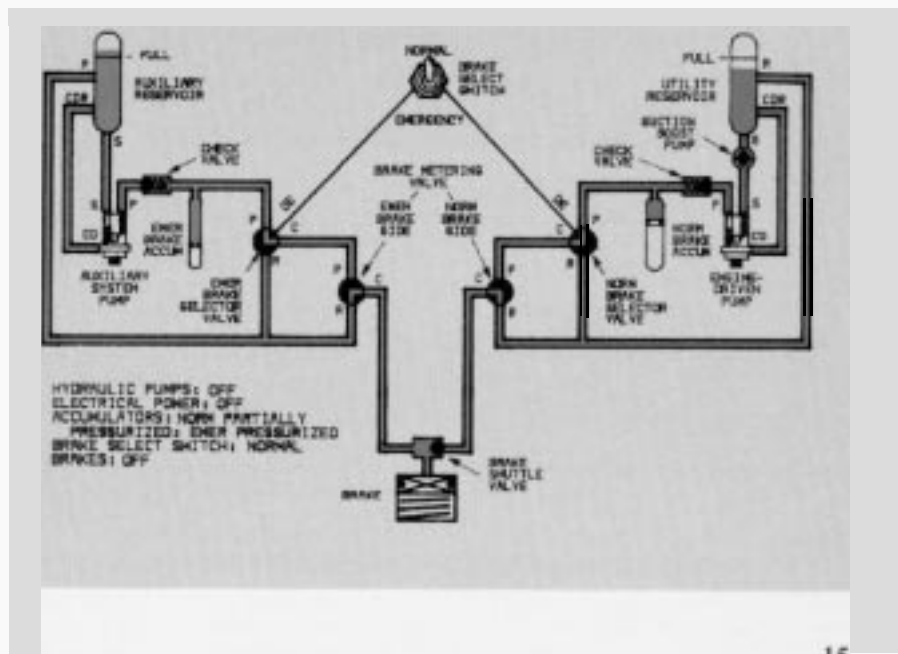

Figure 12. ▲

Figure 13. ▼





**People.
Progress.
The Hercules aircraft is there.**

