

SERVICE NEWS



Lockheed SERVICE NEWS

A SERVICE PUBLICATION OF
LOCKHEED-GEORGIA COMPANY
A DIVISION OF
LOCKHEED CORPORATION

Editor
Charles 1. Gale

Associate Editors
Doug Brashear
James A. Loftin
Vera A. Taylor

Vol. 12, No. 1, January-March 1985

CONTENTS

2 Focal Point

Jim Thurmond
Director of ILS

3 Cargo Ramp Rigging Checks

Making sure your aircraft's cargo ramp is properly rigged makes good sense, both from operational and safety standpoints. This article tells you how.

Cover: The **view out the** back with the ramp and cargo door open is impressive, both in the air and on the ground. The huge 9 ft. by 10 ft. opening helps make the Hercules aircraft the world's most versatile airlifter.

Published by LockheedGeorgia Company, a Division of Lockheed Corporation. Information contained in this issue is considered by Lockheed-Georgia Company to be accurate and authoritative: it should not be assumed, however, that this material has received approval from any governmental agency or military service unless it is specifically noted. This publication is for planning and information purposes only, and it is "at to be construed as authority for making changes on aircraft or equipment, or as superseding any established operational or maintenance procedures or policies. The following marks are registered and owned by Lockheed Corporation: "Lockheed", "Hercules," and "JetStar." Written permission must be obtained from Lockheed Georgia Company before republishing any material in this periodical. Address all communications to Editor, Service News, Department 64-31, Zone 278, Lockheed-Georgia Company, Marietta, Georgia, 30063. Copyright 1985 Lockheed Corporation.

FocalPoint

ILS at Lockheed: Expanding the Tradition

In today's aerospace industry the term "integrated logistics support," or "ILS," has come to have a familiar ring. Unfortunately, this does not mean that the full significance of ILS is always well understood, even by some closely involved with the defense systems acquisition process.



Jim THURMOND

What, exactly, is ILS? There are many formal definitions, but in simplest terms we can say that integrated logistics support is a systematic way of considering and providing for the support requirements of a new product or system in advance. The main goals of ILS are to provide balanced support elements for new systems, control life-cycle costs, and ensure system supportability and readiness.

Why do we have ILS? The U.S. Department of Defense began introducing the use of some ILS concepts in connection with major defense procurement programs as early as the 1960s. Their demonstrated value and rapid progress in the field of logistics has led to an expanding role for **ILS. Today**, virtually every defense systems contract contains specific and detailed ILS requirements.

Who makes up ILS? The nature of ILS requires active participation and commitment of resources on the part of many different groups. At Lockheed-Georgia, organizations with such diverse fields of specialization as customer training, advanced design, customer supply, master scheduling, technical publications, information services, and contract management, among others, are closely involved in the ILS process.

Orchestration of this effort is the task of the Lockheed's ILS organization, which has developed rapidly since the position of director of ILS was established in 1980. Two main areas of emphasis have evolved, each served by its own department. One is concerned with logistics research, developing logistics programs, and advanced ILS program proposals. The other deals with production-oriented programs and provides management integration of all company ILS efforts, beginning with FSED and continuing throughout the life cycle of each system.

The primary objective of an ILS program is to achieve system readiness at an affordable life-cycle cost. The ILS organization at Lockheed-Georgia is dedicated to ensuring that this goal is realized in every program the company undertakes. The techniques of ILS are as modern as tomorrow, but Lockheed's commitment to ILS serves a tradition that goes back more than 50 years: offering our customers maximum value for every dollar spent.

Sincerely,

Jim Thurmond
Director of ILS

PRODUCT SUPPORT

LOCKHEED-GEORGIA COMPANY
MARIETTA, GEORGIA 30063

T. J. CLELAND

DIRECTOR

CUSTOMER
SERVICE

INTEGRATED
LOGISTICS SUPPORT

CUSTOMER
SUPPLY

A. H. McCRUM
DIRECTOR

J. L. THURMOND
DIRECTOR

M. M. HODNETT
DIRECTOR

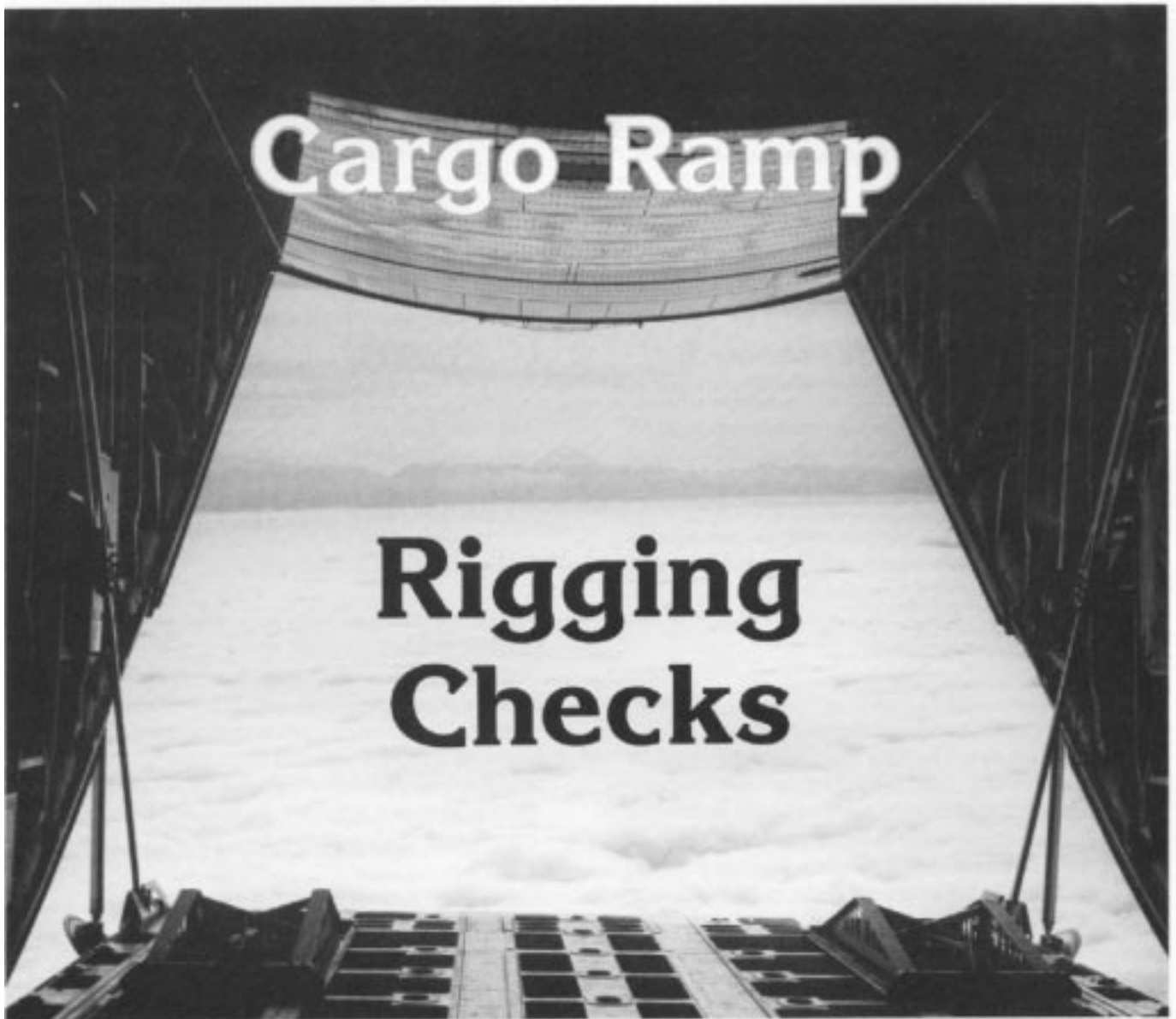

When the Hercules aircraft is in flight, the airframe structure normally undergoes some distortion, which can result in dimensional changes and alteration of relative positions between airframe components. The cargo ramp locking system has been designed to allow for such changes in the aircraft structure. To do its job effectively, the system must be properly aligned and rigged. Experience has shown that inflight pressurization leakage around the cargo ramp can result from improper alignment and rigging of the ramp locking system.

If you suspect that your aircraft is suffering from ramp locking system difficulties, make the following checks. When the requirements of each of these items has been met, the cargo ramp locking system is adjusted and operating properly. If the requirements are not met, refer to the appropriate maintenance manual and take corrective action.

Note that the ramp rigging step numbering sequence is the same in all of the applicable maintenance manuals with the exception of the C-130A manual. For this reason, the rigging steps referred to in this article are given by number (Step 1, Step 2, etc.).

Safety First

In order to conduct the following checks and adjustments safely, the cargo ramp and door should be deactivated as follows.

- Place the aft cargo door in the closed (down) position.
- Place the aft cargo door valve handle in the NEUTRAL position and red-tag the handle around the spring lock to prevent unintentional operation of the door during the ramp rigging checks.

- Open the HYD PUMP AUX SYS circuit breakers (phases **A**, **B**, and **C**) on the pilot's circuit breaker panel and the RAMP AND ADS CONT circuit breaker on the aft fuselage junction box. Red-tag the circuit breakers. This will prevent the auxiliary hydraulic pump motor and ramp control valve from inadvertent operation, which could cause damage to the aircraft or injury to personnel during this procedure.
- As an added precaution, disconnect the electrical connector from the auxiliary hydraulic pump and tag the pump with a notice that the connector has been disconnected.

After complying with these safety precautions, movement of the ramp and ramp locking mechanism must be accomplished by using the auxiliary hydraulic system hand pump.

When using the manual ramp control, be sure to rotate the knob only in a clockwise direction so that it will remain in sequence with the internal valves.

Inspecting Ramp Components

Start the ramp rigging check by removing the ramp hook actuator access panel and the ramp treadway (Figure 1) to gain access to the locking mechanism. It would be wise to go ahead with cleaning and lubrication of the ramp locking system components according to the applicable maintenance manual before proceeding. Also inspect all hooks, bellcrank assemblies, switches, springs, catches, and the ramp switches to ensure freedom of movement without binding or interference with adjacent structure.

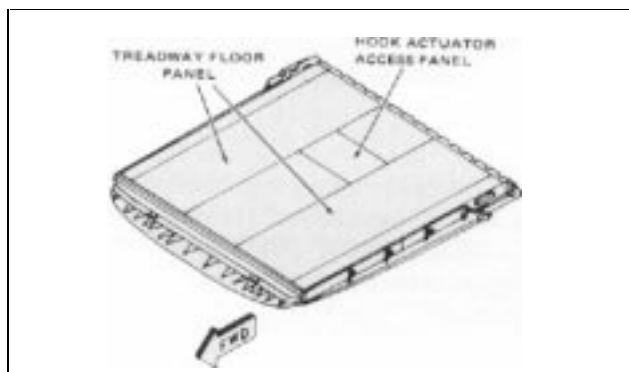

Figure 1. Ramp access panels.

1. RAMP HOOK ACTUATOR CHECK

Use the auxiliary hydraulic system hand pump to move the actuator bellcrank to the locked position as shown in Figure 2. Apply and maintain 500 to 1000 psi pressure while checking for a no-gap condition between the bellcrank and the actuator bellcrank locked stop. Full contact is not required along the

stop, but the actuator bellcrank must contact the actuator bellcrank stop at some point. If the bellcrank does contact the stop, then perform the same check of the actuator in the unlocked position. Be sure to maintain 500-1000 psi hand-pump pressure, and verify that positive contact is made between the actuator bellcrank and the actuator bellcrank unlocked stop.

If the actuator bellcrank did not contact both stops:

- Verify that 500-1000 psi was maintained during the gap checks.
- Check for a damaged or out-of-tolerance ramp hook actuator, actuator support fitting, or actuator bellcrank. Replace as necessary.
- Check for mislocated stops, actuator support fittings, or actuator bellcrank pivot bolts. Take appropriate corrective action.

When contact with both stops has been checked and verified, proceed with the next operation.

Note: Ramp rigging Checks 2,3, and 4 may be accomplished with the ramp hook actuator removed. If the actuator is removed, a clamp must be used to secure the actuator bellcrank to its locked or unlocked stops during these procedures. Reinstall the actuator before proceeding to ramp rigging Check 5.

2. RAMP HOOK BELLCRANK TO STOP CLEARANCE CHECK

With the ramp down and the ramp locking mechanism in the full locked position, check for a maximum of 0.03-inch clearance between each ramp hook bellcrank and its respective stop (Figure 3). While measuring each ramp hook location, be sure to apply some pressure on the hook bellcrank in an inboard direction as shown in Figure 3 to remove any slack from the system. If all ramp hook bellcranks have the required clearance, proceed with the next check. If not, it would be wise to go ahead and re-rig all the hook push rods, connecting rods and control rods as specified in maintenance manual ramp rigging Steps 1 through 23.

3. RAMP HOOK MAXIMUM EXTENSION CHECK

Move the actuator bellcrank to the actuator bellcrank unlocked stop and secure it (see Figure 2). Using a spring scale as shown in Figure 4, pull outboard on each ramp hook with a force of approximately 5 pounds while measuring the extension of the hook

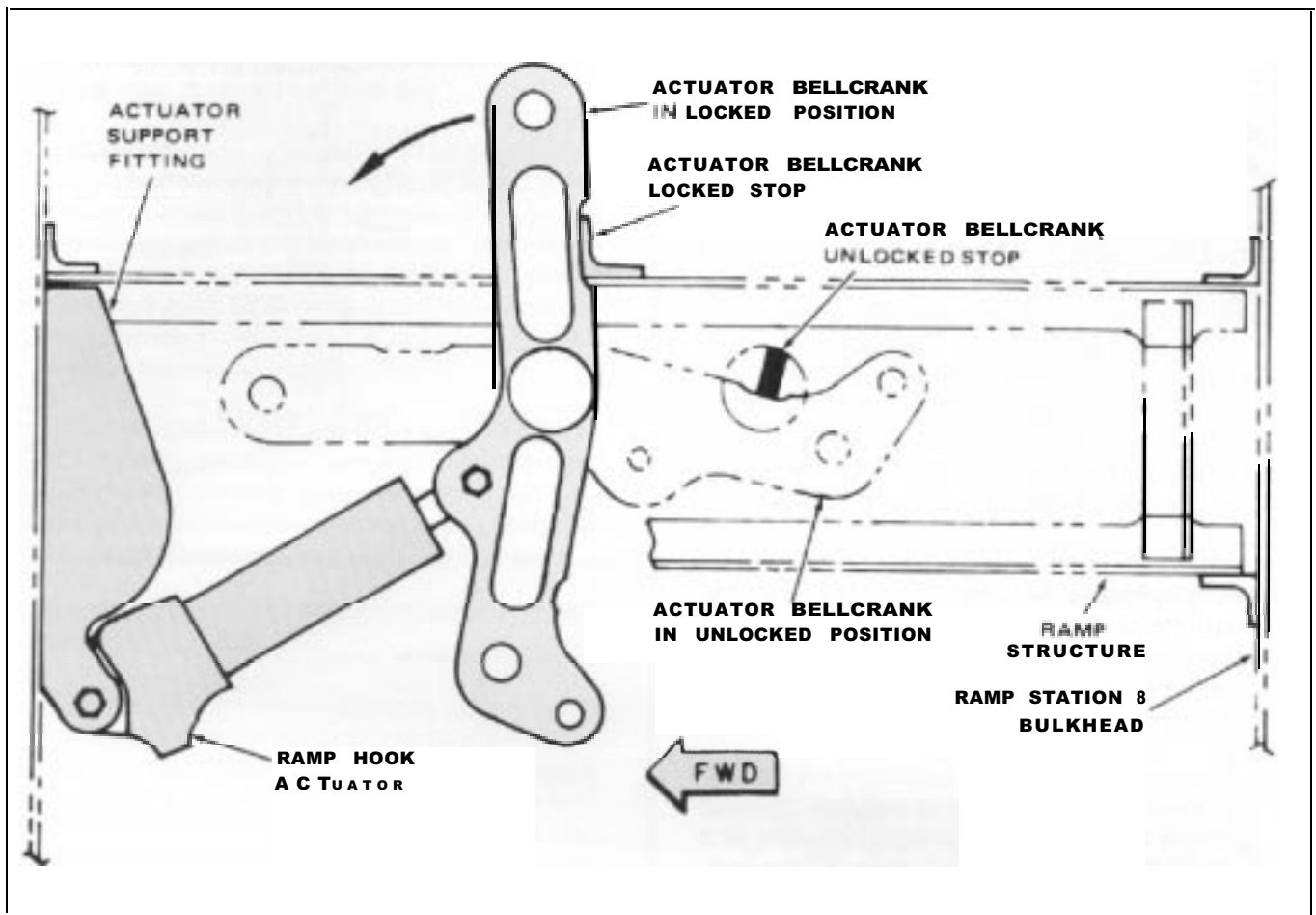

Figure 2. Ramp hook actuator bellcrank.

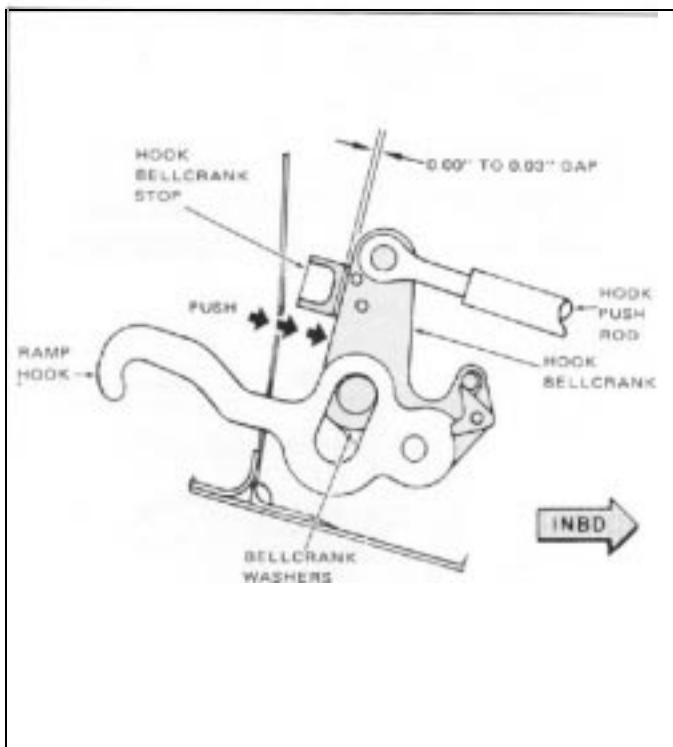

Figure 3. Ramp hook bellcrank stop clearance.

beyond the outboard face of the ramp web. If any ramp hook extends beyond the maximum dimension of 0.50 inch, check for the correct bolt diameter in the rod ends of the pushrod, connecting rod and control rod, and out-of-tolerance hooks, bellcranks, rods, or rod end bearings. Replace as necessary.

4. HOOK MOVEMENT AND MINIMUM SPRING FORCE CHECK

Move the actuator bellcrank to the actuator bellcrank locked stop (see Figure 2) and secure it.

Check the ramp hooks for freedom of movement between the hook bellcrank washers without binding or scraping (see Figure 3). The hooks must be relatively loose between the hook bellcrank washers. If binding occurs:

- Check areas around the hook and bellcranks for dirt or foreign materials.
- Check ramp hook and hook bellcrank for damage or out-of-tolerance parts. Replace faulty components as necessary.

Spring Force Measurement

Use a spring scale as shown in Figure 5 to check the vertical pull required to move each hook up until it contacts the bellcrank. While pulling the hook up, note the force required to overcome the spring on the small catch located at the lower end of the hook bellcrank (see Figure 5). This force must be 5 pounds minimum. If the force measured is less than 5 or more than 15 pounds, make the following checks:

- Check for faulty catch, catch spring, or ramp hook. Replace unserviceable parts.
- Check for binding of the hook on the bellcrank washers or binding of the hook pivot point.

The proper operation of the small catch is vital for proper locking of the cargo ramp hooks. The function of this catch is to move the lower part of the hook inboard, which in turn moves the upper part of the hook outboard with the first movement of the hook bellcrank toward the locked position.

If the hook is not free to move between the bellcrank washers or if the force to overcome the catch spring is less than the minimum requirement of 5 pounds, the hook will not move to the correct intermediate locking position shown in Figure 6. As a result, the ramp hook will not properly engage the hook retainer but will instead (Figure 7) bind on the lip of the hook retainer as shown (Figure 8). Note the difference between *correct* path of the hook tip shown in Figure 6 and the *incorrect* path of the hook tip shown in Figure 8, where the hook first moves down, then outboard, binding on the hook retainer. The correct hook movement is first outboard, clearing the tip of the hook retainer, and then down to the locked position shown in Figure 7.

When all the ramp hooks move freely between their respective bellcranks and the force required to overcome the spring tension on the small catches is between 5 and 15 pounds, you have completed this check and are ready to move on to the next one.

5. RAMP LOCK POSITIONING ROD CHECK

Place the ramp lock actuator bellcrank in the intermediate position which will cause the greatest compression of the ramp lock positioning rod (see Figure 9). Check to see that the forward spring retaining pin washer clears the inner edge of the forward slot in the positioning rod tube by 0.01 to 0.06 inch as shown in View AA of Figure 9. When checking for the 0.01-to 0.06-inch dimension, slide the positioning rod tube

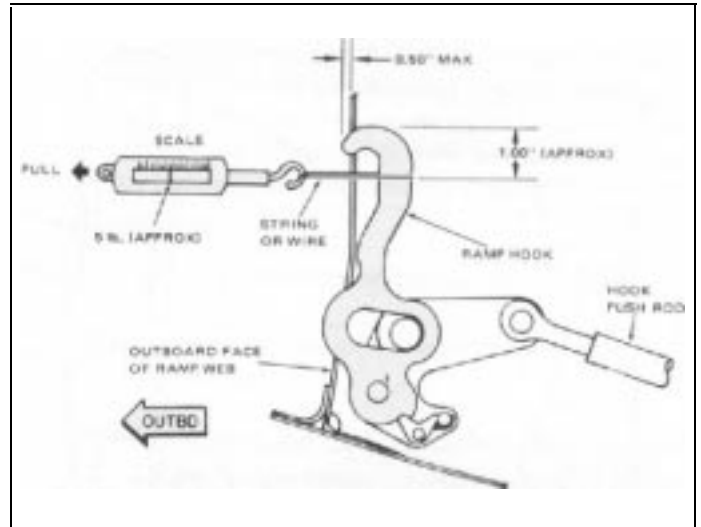

Figure 4. Ramp hook maximum extension check.

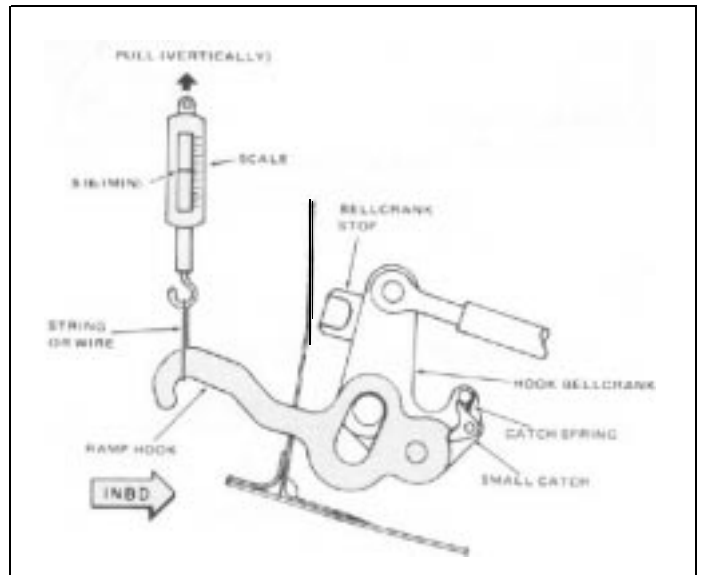

Figure 5. Ramp hook vertical pull.

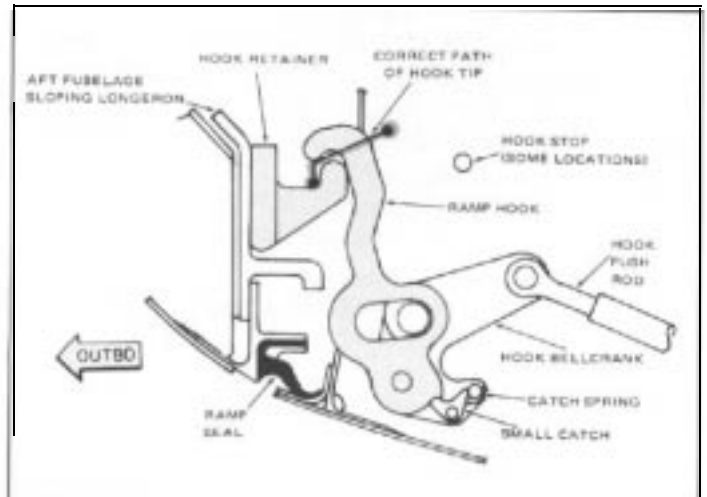

Figure 6. Correct hook movement.

in the direction indicated in View AA of Figure 9 so that the aft spring retaining pin will contact the in-board edge of the aft rod tube slot.

If the ramp lock positioning rod spring retaining pin washer clearance exceeds the 0.01- to 0.06-inch tolerance, loosen the rod end jam nuts and adjust the positioning rod as required to bring it within the specifications. After adjusting, verify proper thread engagement on both ends and tighten the rod end jam nuts to a torque of 95-110 inch-pounds. Refer to maintenance manual ramp rigging Step 39.

The internal ramp rigging checks are now complete. If your ramp has passed these first five checks, you may reinstall the ramp hook actuator (if removed), and position the actuator and bellcrank to the unlocked position.

6. RAMP CYLINDER FITTING FABRIC PATCH IMPRINT CHECK

For this check it will be necessary to replace the fabric patches on the ramp cylinder fitting with new patches, P/N 353613-31, or fabricate them locally from specifications found in the maintenance manual ramp rigging procedures beginning at Step 42. The new patches are needed to provide an indication of proper contact with the phenolic stops on the aircraft structure when the ramp is closed. The existing patches may show an indication of proper contact, but the only way to know if the ramp is still closing properly and contacting the phenolic stops is to install new fabric patches and make the following check.

- Be certain that the ramp area is cleared for closing. Ensure that all foreign objects such as air hoses, electrical cords, tools, and personnel are removed from the cargo ramp and surrounding area.

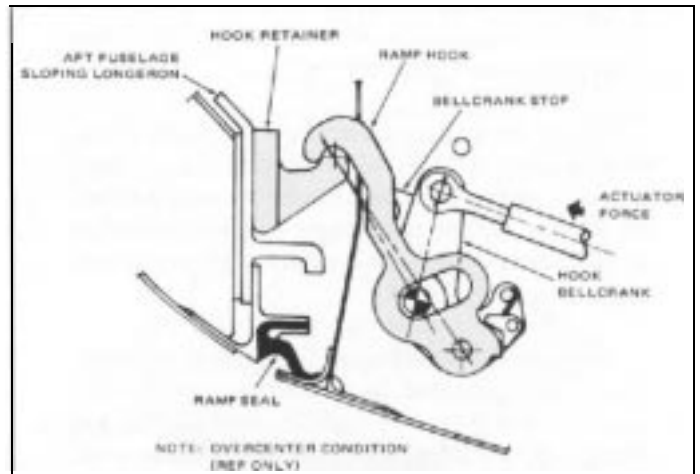

Figure 7. Ramp hook correct locked position.

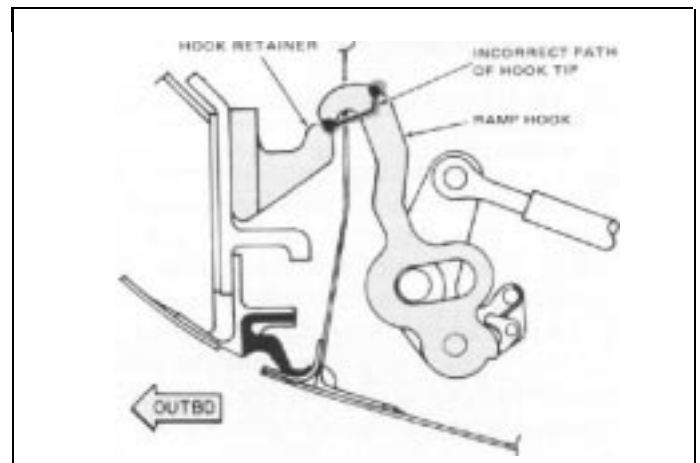

Figure 8. Ramp hook incorrect movement.

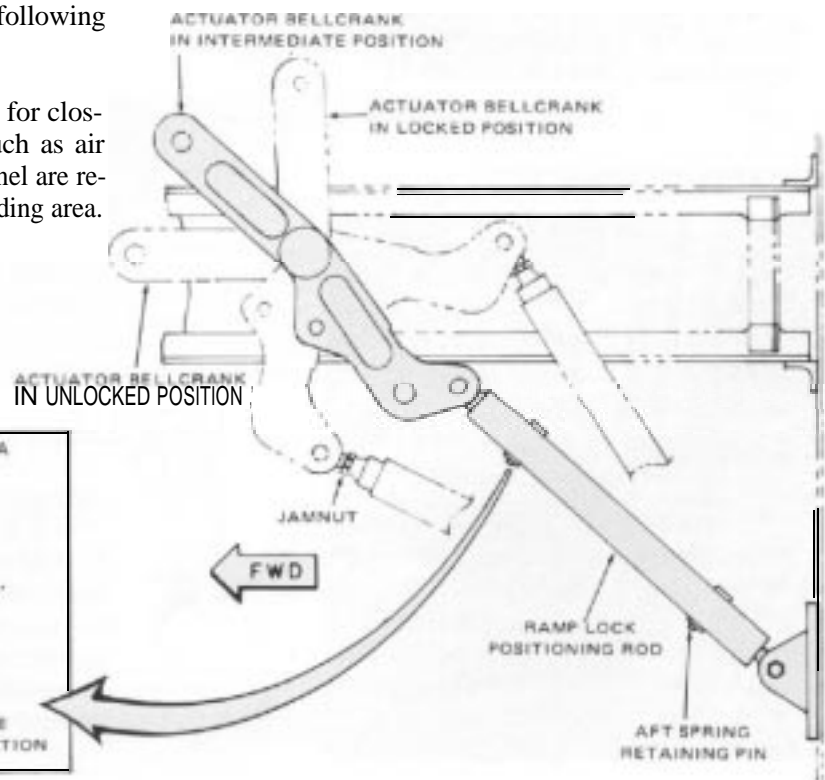
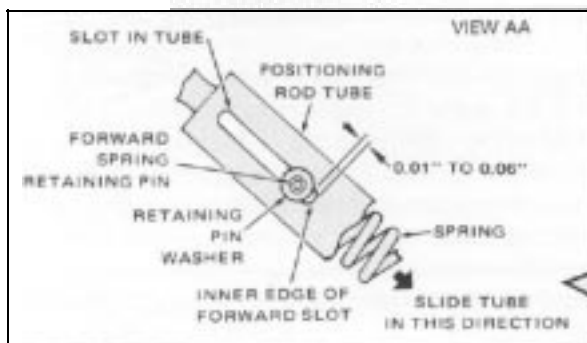

Figure 9. Ramp lock positioning rod.



- Verify that ramp hooks are in the unlocked position. They should be retracted and in the ramp structure (see Figure 10).

Now rotate the manual ramp control knob clockwise to select RAMP UP and, using the auxiliary hydraulic system hand pump, raise the ramp and apply 2000 to 3000 psi to the ramp hydraulic cylinders to fully close the ramp. Do not operate the ramp hook locking mechanism yet.

Lower the ramp and inspect the fabric patches (see Figure 11). Note that an impression of the entire phenolic stop is not required. If no impression has been made in the fabric patch by the phenolic stop, it will be necessary to adjust the ramp actuator rod ends according to maintenance manual ramp rigging Steps 47 and 48. If an impression is visible on both fabric patches, proceed with the next check.

7. RAMP HOOK RETAINER DIMENSION CHECK

Use a 10-foot measuring tape as shown in Figure 11, and record the dimensions between the left and right hook retainers at ramp stations 2, 4, 6, 8 and 10. Note the ramp station with the smallest dimension and compare it with the dimensions at the other ramp stations. Identify the ramp stations where the recorded dimension is greater than the smallest dimension by 0.06 inch or more. If all ramp station dimensions are equal within a tolerance of ± 0.06 inch, proceed with the next check. If not, it will be necessary to shim behind the offending ramp hook retainer (Figure 13) fittings to bring them within the tolerance. This procedure is specified in maintenance manual rigging Steps 50 through 55.

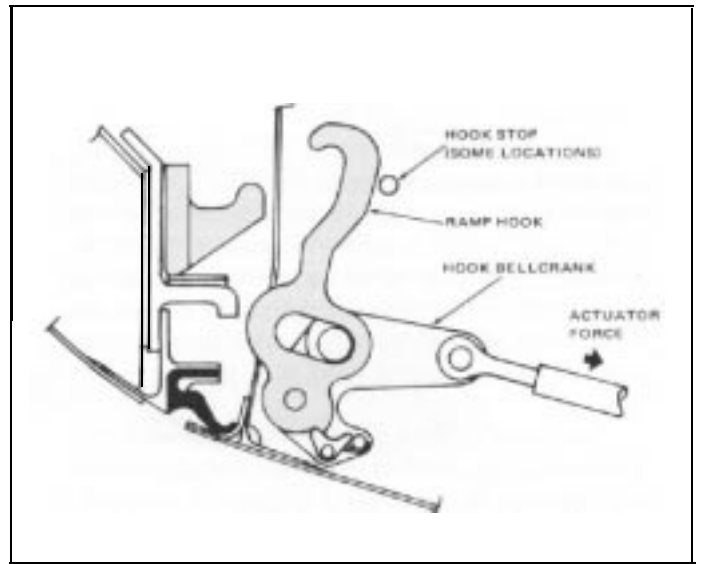

Figure 10. Ramp hook fully retracted position.

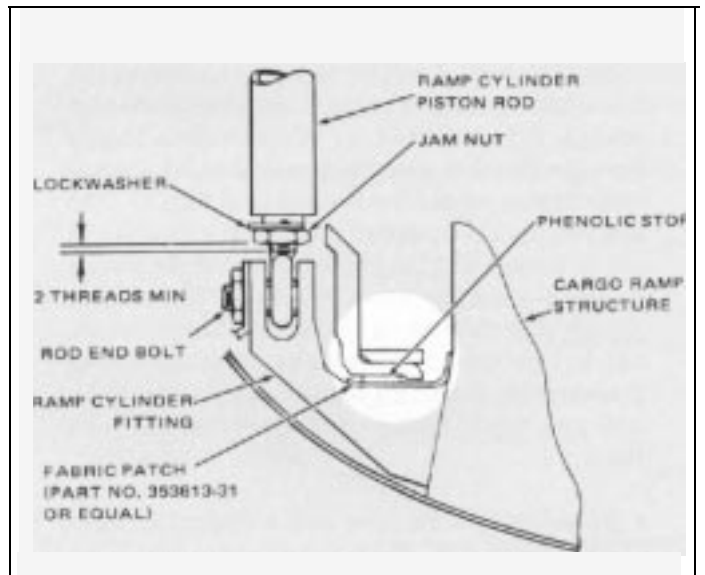

Figure 11. Fabric patch and phenolic stop.

IMPRESSION ON FABRIC PATCH

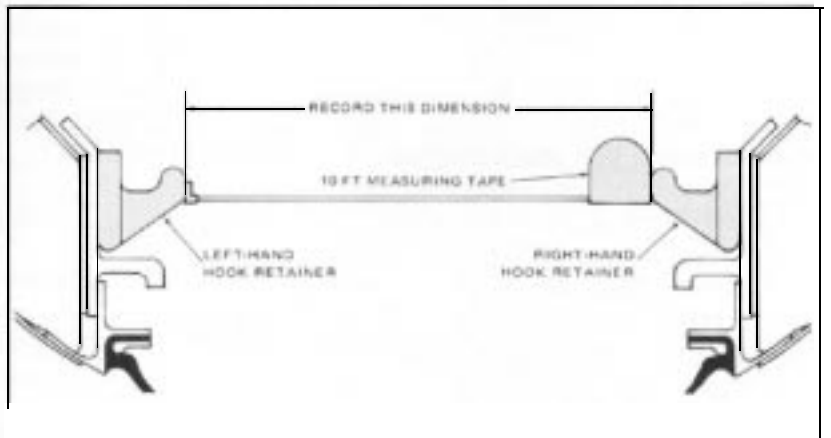
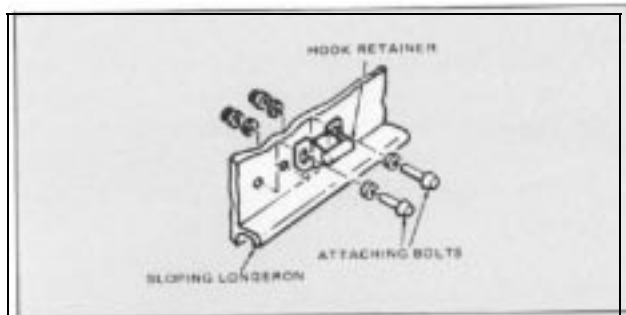

Figure 12. Measuring distance between left and right hook retainers.

8 RAMP HOOK TO HOOK RETAINER DIMENSION CHECK

Ramp Station 10

Remove all foreign objects from the ramp area and verify that the ramp hooks are in the unlocked position. Next raise the ramp using the hand pump until it is in the full up and locked position. Check the ramp hooks at ramp station 10 to verify that no gap exists between the left and right ramp hooks and their respective hook retainers. This can be done by visually checking for good contact between the ramp hook and hook retainer. Then use firm hand pressure to determine whether the ramp hook can be moved a slight amount fore and aft. If no movement exists, the station 10 ramp hook retainers will require no attention. If some movement is detected, refer to maintenance manual ramp rigging Steps 56 through 66 for corrective procedures.



HOOK RETAINER INSTALLATION

Ramp Stations 2, 4, 6, and 8

Next pull up on the ramp hook, using firm hand pressure, and attempt to pass a 0.06-inch diameter wire between the eight ramp hooks at ramp stations 2, 4, 6, and 8, and their respective hook retainers (Figure 13). If the 0.06-inch diameter wire fits between any of the ramp hooks and hook retainers, it will be necessary to add one additional 0.032-inch shim under that hook retainer (see Figure 14) according to maintenance manual rigging Steps 76 and 77. Check each of these eight ramp hooks also for a small amount of fore and aft movement, using firm hand pressure. This small amount of movement should indicate the existence of the minimum gap of 0.01 inch. If this checks out correctly, proceed with checking ramp locking pressure as directed below. If not, refer to maintenance manual rigging Steps 74 and 75. Now unlock the ramp (if locked); then use the auxiliary system hand pump to check the pressure required to cause the ramp locking mechanism to go into the locked position. It should lock at 500 to 1200 psi. If not, perform ramp rigging Steps 50 through 80 in the maintenance manual.

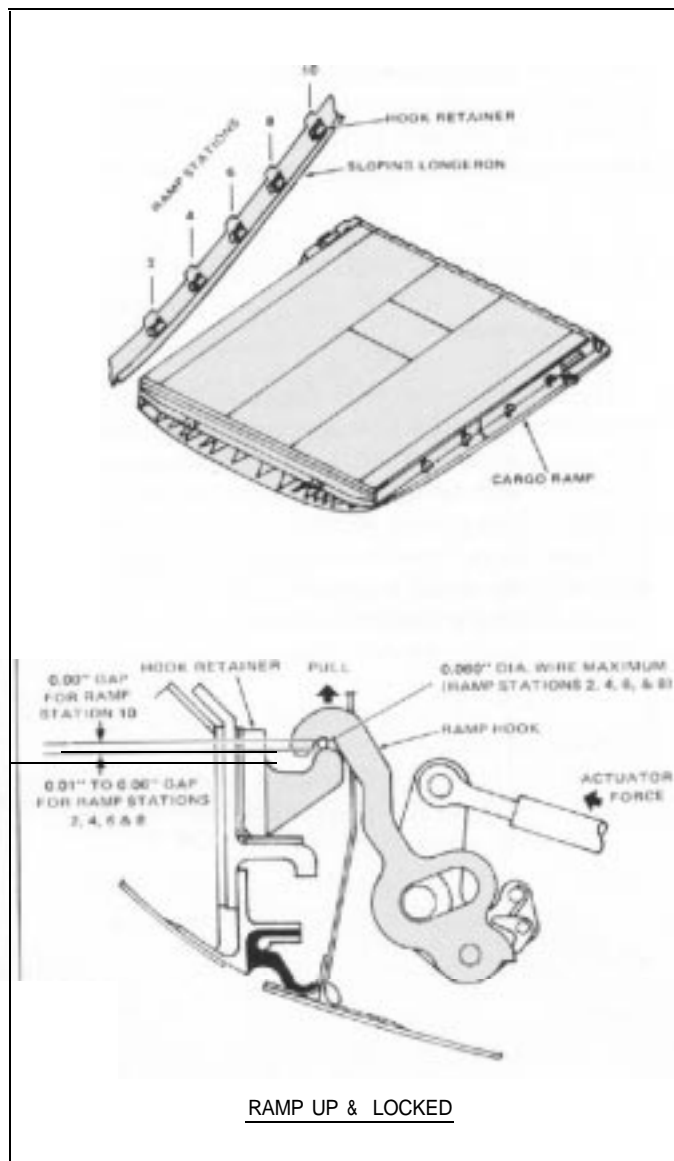

Figure 13. Hook to retainer gap check.

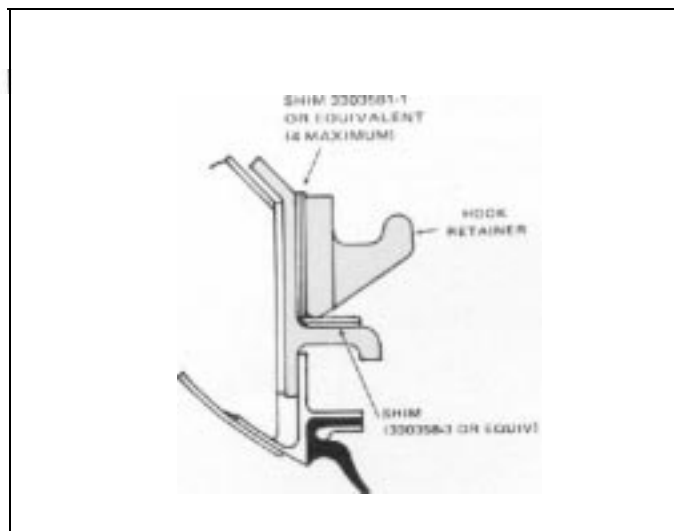

Figure 14. Hook retainer shims.

Verify that the hook retainers for ramp stations 2, 4, 6, and 8 meet the 0.01 to 0.06-inch gap requirements (see Figure 13) previously mentioned. Also inspect the hook retainers to be sure that they are all in full contact with the lower shims, and check the lower shims to be sure all have their retainer screws installed.

9. RAMP SWITCH ADJUSTMENT CHECKS

Switch Overtravel

These checks are to verify the proper switch overtravel dimensions that have been set on the hook lock switches, hook unlock switch, ramp up switches and, on aircraft with the Automatic Deployment System (ADS), the ramp down switch. Switch overtravel is the linear distance that the switch plunger moves inward after the switch is actuated. There are several ways to determine the point of switch actuation. The simplest is to listen for the “click” made by the switch mechanism. It should be noted that an informal trial of this method on three aircraft in a production environment revealed that the switch mechanisms were not noisy enough to be heard by the unaided ear. If one is available, a stethoscope would be handy for enhancing the sound of switch actuation.

A test light or ohmmeter is really the best way to detect switch actuation, however this requires that the ship’s wiring be disconnected from the switch or the appropriate terminal block or connector (such as TB9 or 5208). Then connect the ohmmeter or test light probes to check continuity across the switch contacts. Refer to the appropriate wiring diagram in the aircraft maintenance manual.

The inspection and, if required, adjustment of the various ramp switches can be done in any convenient order; that is, you may check the ramp up switch first or the hooks locked switch first, etc.

- *Ramp hook actuator locked and unlocked switches* overtravel dimensions should be 0.47 to 0.53 inch for the hooks locked switch and 0.22 to 0.28 inch for the hooks unlocked switch and should be measured as shown in Figure 15. If adjustment is required, refer to maintenance manual ramp rigging Steps 24 thru 37.
- *Ramp up switches* are both adjusted to an overtravel tolerance of 0.12 to 0.18 inch as shown in Figure 16. This is fairly easy to measure. Checking one side at a time, use the hand pump to move the ramp down slightly from the up and locked posi-

Figure 15. Hooks locked and hooks unlocked switches.

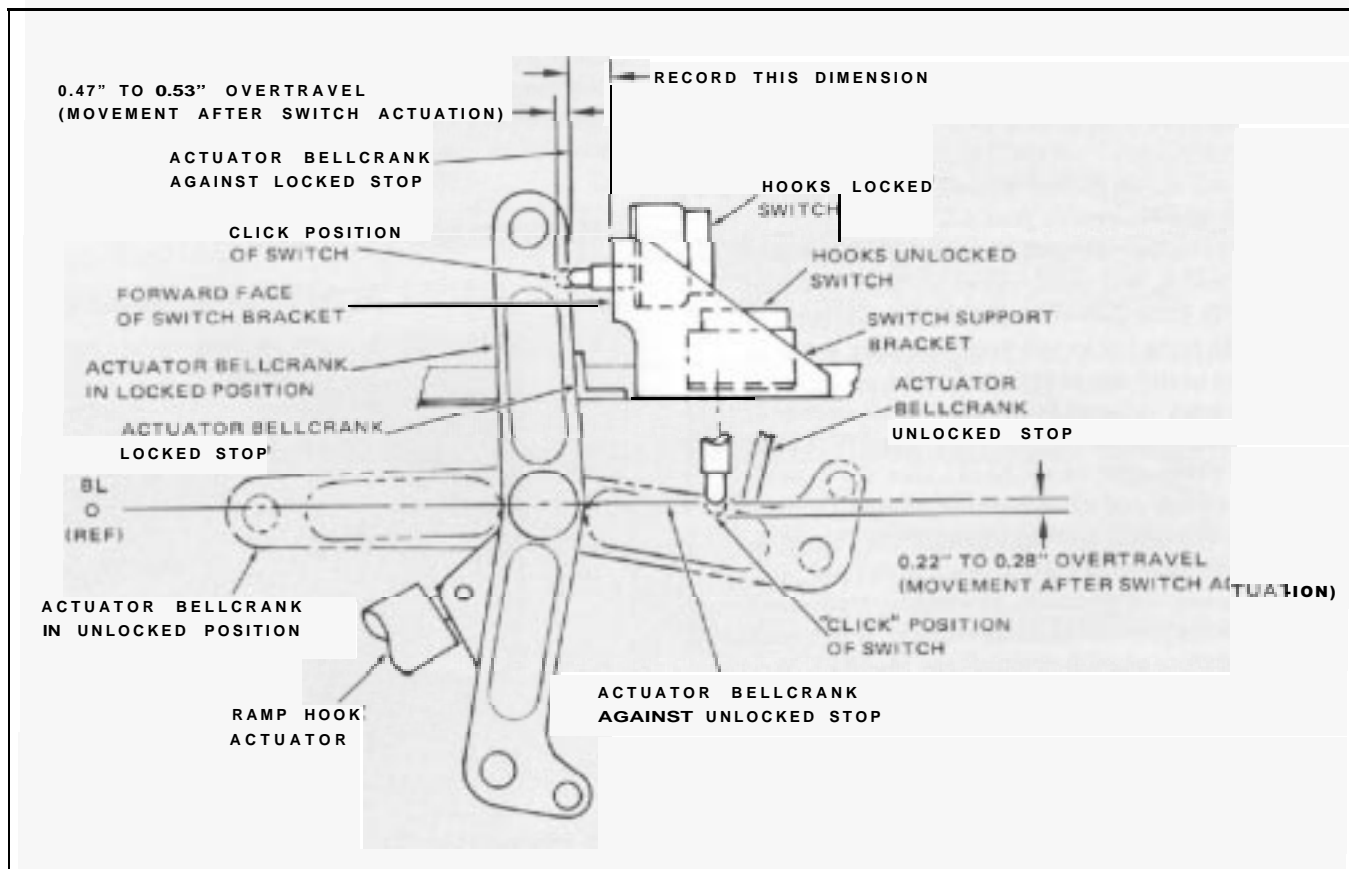

tion, then carefully back upward until the audible “click” of the switch can be heard or the test light indicates switch actuation. Stop the ramp movement at the exact moment of switch actuation (this is the tricky part) and measure the distance between the lower surface of the switch support bracket and the striker bracket. A 6-inch steel rule will work nicely for this measurement.

Now pump the ramp to the full up and locked position and measure again between the switch bracket and the striker bracket. The difference between these two measurements should fall within the 0.12-to 0.18-inch overtravel tolerance. If not, refer to maintenance manual ramp rigging Steps 81 through 93.

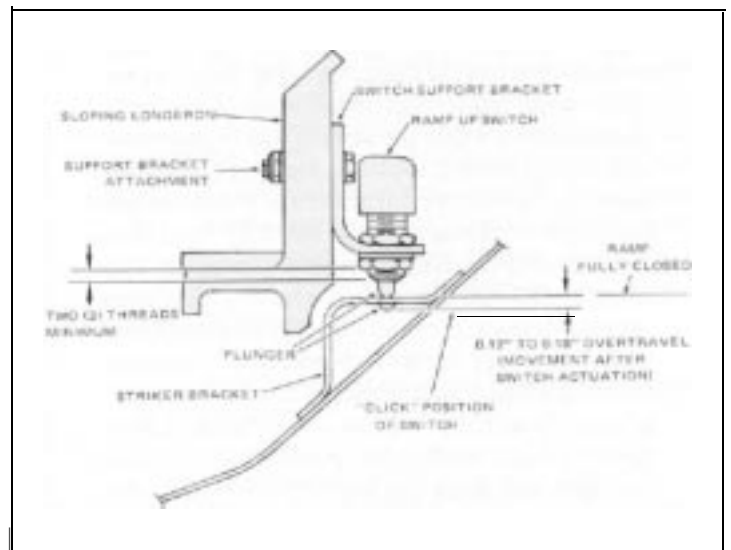
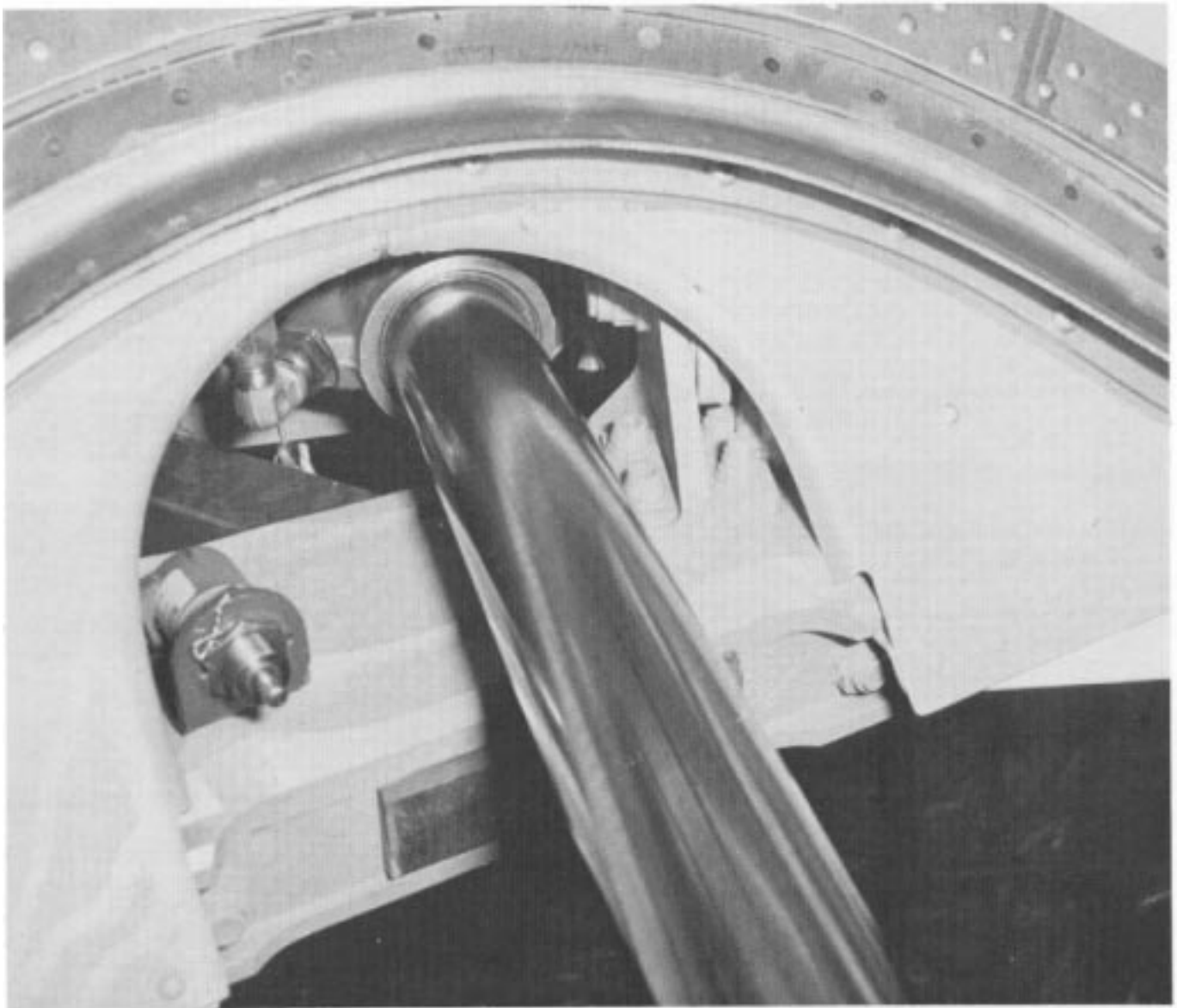

Figure 16. Ramp up switch.

RAMP UP SWITCH LOCATION



- The cargo ramp hooks locked switches located at both ramp station 10 hook retainers should first be inspected to verify that the hook feeler is centered within ± 0.06 inch on the ramp hook. Next, check to be sure that the vertical gap requirement of 0.05 to 0.15 inch shown in Figure 17 exists between the end of the hook feeler and the upper surface of the hook retainer. Now check for the 0.10-to 0.15inch overtravel requirement on the switch. This is not as difficult as it at first appears. Here is an easy way to do it. First, unlock the ramp and lower it slightly to get the ramp hooks out of the way. On both left and right sides, push in the hook feeler carefully until the switch operates (“clicks”), hold the hook feeler exactly where it was when the switch actuated, and mark the hook retainer on its end to show this relative location. Next, hand pump the ramp back to the up and locked position. Go back and mark the relative position of the hook feelers on the end of the hook retainers on both sides. Measure the distance between the first and second mark on each hook retainer. This dimension should be 0.10 to 0.15 inch. if it is not, refer to maintenance manual ramp rigging Steps 94 through 102 for switch adjustment.

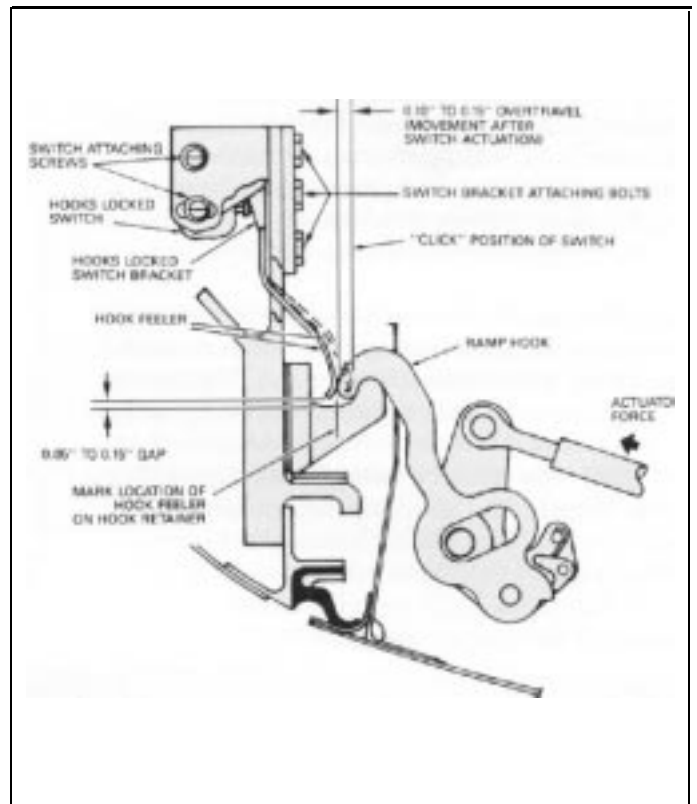
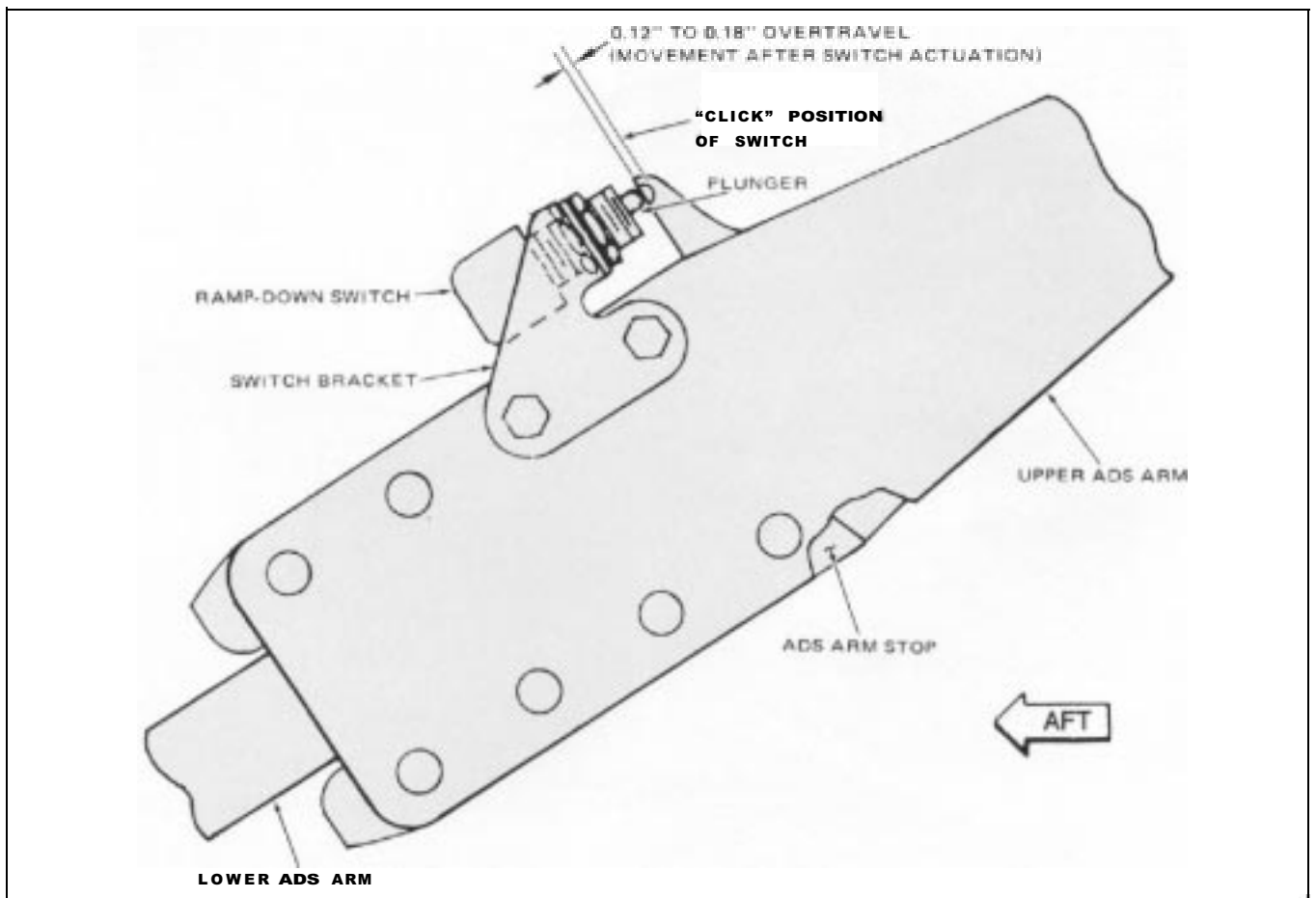

Figure 17. Hooks locked switch.

Figure 18, Ramp down switch.



- The ramp down switch is located on the left ADS arm or “grasshopper arm”. Measure the overtravel on this switch to see if it falls within the tolerance of 0.12 to 0.018 inch as shown in Figure 18. One way to accomplish this check would be to raise the ramp, then depress the switch plunger, using firm finger pressure, until the switch actuates. Hold the switch at the position of actuation while marking the switch plunger at the point where it enters the switch housing. Now lower the ramp and make another mark on the switch plunger in the same relative position. Raise the ramp and measure the distance between your two marks on the switch plunger. The measurement should be between 0.12 and 0.18 inch. If not, refer to maintenance manual ramp rigging Steps 103 through 109 for switch adjustment procedures.

When all of the ramp switches are in compliance with these requirements, proceed with the final check.

10. RAMP HOOKS CHECKS

Ramp Station 2 Hooks

- Close and lock the ramp. All the hooks will lock.
- Identify the right and left forward connecting rods by marking or tagging the forward portion of the rod “ramp station 2 right” and “ramp station 2 left” as applicable; then remove the rods.
- Unlock the ramp. The ramp station 2 hooks should remain locked. All other hooks will unlock.
- Check the inboard arms of the station 2 rod bellcranks, using firm hand pressure to verify that they are in the aftmost position. Now use the hand pump to attempt to lower the ramp. Slowly increase the applied pressure to a *maximum* of 100 psi. Verify that the hooks remain locked; then release the pressure from the ramp cylinders.
- Lock the ramp, then reinstall the forward connecting rods, tightening fasteners only finger-tight at this time.

Ramp Station 10 Hooks

- Identify and remove the right and left aft connecting rods (Figure 19).
- Unlock the ramp. Only the ramp station 10 hooks should remain locked. All others should be unlocked.

- Use firm hand pressure to verify that the inboard arms of the rod bellcranks for the ramp station 10 hooks are in the aftmost position. This ensures that the hook bellcranks for the station hooks are positioned against the hook bellcrank stops (see Figure 19). Use the hand pump to slowly apply 500 psi *maximum* pressure to the ramp cylinders, attempting to lower the ramp. If both hooks are in the proper overcenter position, they will remain locked while this pressure is applied to the cylinders.
- Remove the left and right side forward connecting rods.
- Lock the ramp. Only the ramp station 2 hooks will remain unlocked.
- Reinstall the aft connecting rods, tightening fasteners only finger-tight at this time.

Ramp Station 4 Hooks

- Identify and remove the left and right side center forward connecting rods (Figure 19).
- Unlock the ramp. The ramp station 4 hooks will remain locked while **all** other hooks will be unlocked.
- Push aft on the ramp station 4 rod bellcrank inboard arm to verify that the hook bellcrank is against its stop. Now slowly apply a *maximum* of 200 psi ramp down pressure. Verify that the hooks remain locked; then remove all pressure from the system.
- Remove the right and left aft connecting rods.
- Lock the ramp. Only the ramp station 2 and ramp station 10 hooks should remain unlocked.
- Reinstall the left and right center forward connecting rods. Fasteners may be installed finger-tight at this time.

Ramp Station 8 Hooks

- Identify and remove the right and left center aft connecting rods (Figure 19).
- Unlock the ramp. The ramp station 8 hooks will remain locked while all other hooks will unlock.
- Push aft on the ramp station 8 rod bellcrank inboard arm to verify that the hook bellcrank is

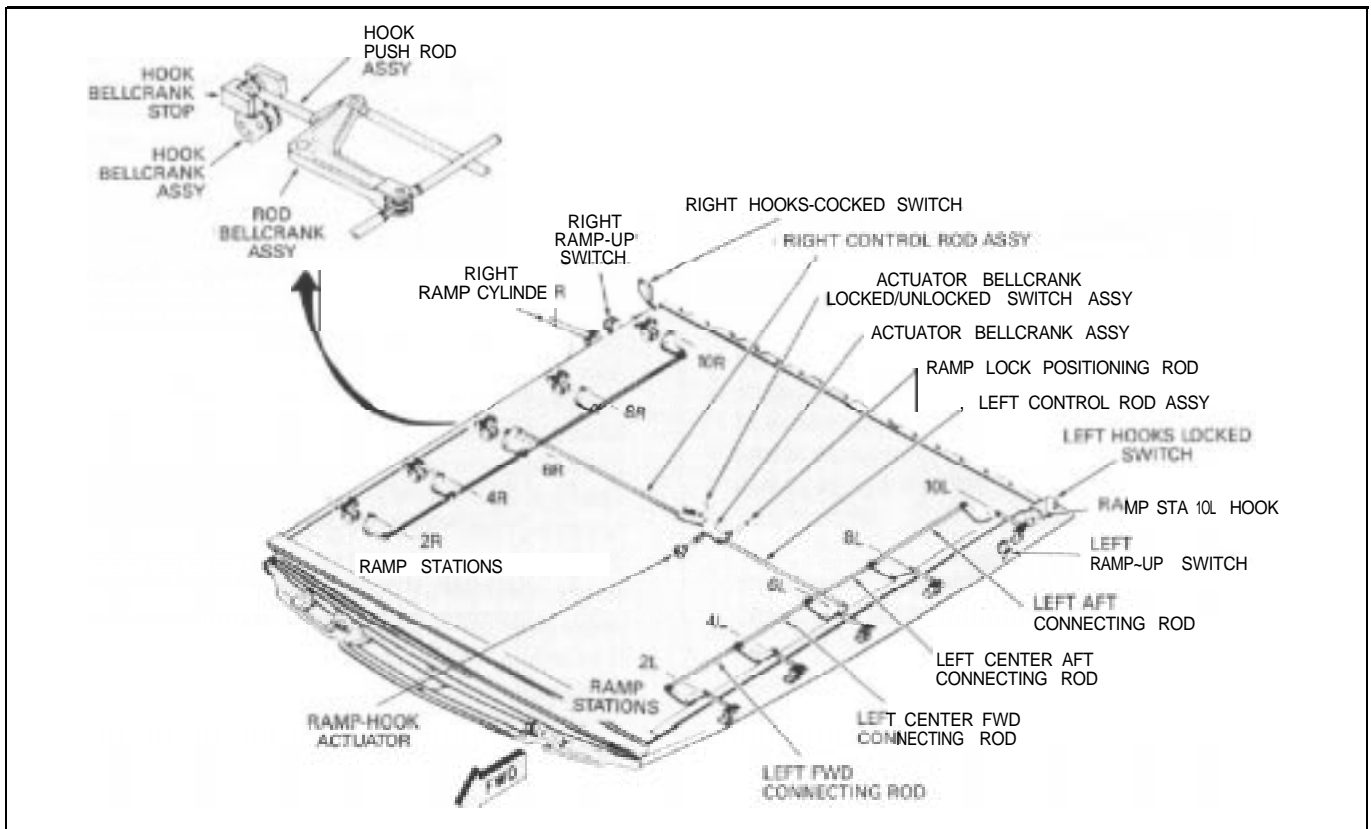

Figure 19. Ramp locking system components.

- d. Remove the right and left center forward connecting rods.
- e. Lock the ramp. The ramp stations 2, 4, and 10 hooks will remain unlocked.
- f. Reinstall the right and left center aft connecting rods. Fasteners may be installed finger-tight at this time.

Ramp Station 6 Hooks

- a. Unlock the ramp and all hooks will be unlocked.
- b. Remove the right and left center aft connecting rods (Figure 19).
- c. Now, lock the ramp and only the ramp station 6 hooks will lock.
- d. Remove the attaching hardware common to the right and left control rods and ramp station 6 rod bellcrank.

- e. Use firm hand pressure and push aft on the in-board arm of both ramp station 6 rod bellcranks to verify that the hook bellcrank is positioned against the hook bellcrank stop. Slowly apply a **maximum** of 300 psi ramp down pressure. Verify that the ramp station 6 hooks remain locked. If they do, the ramp **hook test is complete**. All that remains to be done is reinstallation of the control and connecting rods that were removed during the tests and tightening fasteners.

Reinstallation of Control and Connecting Rods

- a. Before starting the reinstallation, ensure correct placement of the removed items by checking the location markings you put on them earlier.
- b. Reinstall the left and right control rods back to their respective right and left ramp station 6 rod bellcranks. Tighten the attaching hardware on the control rod ends one castellation on the nut past finger-tight as required to align the castellations with the drilled shank of the bolt for cotter pin installation. Do not overtighten.
- c. You may choose to unlock and lower the ramp at this time to facilitate installation of the remaining ramp components previously removed (see

Figure 19). Reinstall the left and right center aft connecting rods in the ramp station 6 rod bellcranks lower clevis, and in the lower clevis of the ramp station 8 rod bellcranks. Install the attaching hardware and tighten the nuts only as required to eliminate end play in the bolt. Be careful not to overtighten.

- d. Reinstall the right and left center forward connecting rods in the upper clevis of the ramp station 6 rod bellcranks, and the lower clevis of the ramp station 4 rod bellcranks. Install the attaching hardware and tighten the nuts only as required to eliminate end play in the bolt. Do not overtighten.
- e. Reinstall the aft connecting rods in the upper clevis of the ramp station 8 rod bellcranks, and in the upper clevis of the ramp station 10 rod bellcranks. Install the attaching hardware and tighten the nuts only as required to eliminate end play in the bolt. Be careful not to overtighten.

- f. Reinstall the forward connecting rods in the upper clevis of the ramp station 4 rod bellcranks, and in the lower clevis of the ramp station 2 rod bellcranks. Install the attaching hardware and tighten the nuts only as required to eliminate end play in the bolt. Do not overtighten.

Operate the ramp, using the auxiliary hydraulic system hand pump, to verify proper operation of the ramp locking mechanism through one complete cycle (opening, closing, and locking). Then reinstall the ramp hook actuator access panel and ramp treadway. Reconnect the electrical connector to the auxiliary system hydraulic pump and close the HYD PUMP AUX circuit breakers (phases A, B, and C), and the RAMP AND ADS CONT circuit breaker.

This concludes the ramp rigging checks. It is important to keep in mind that the maintenance manual applicable to your aircraft should always be referred to when performing these checks and, if necessary, adjustments. When your cargo ramp meets the requirements of these checks your ramp is properly rigged.

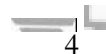

4

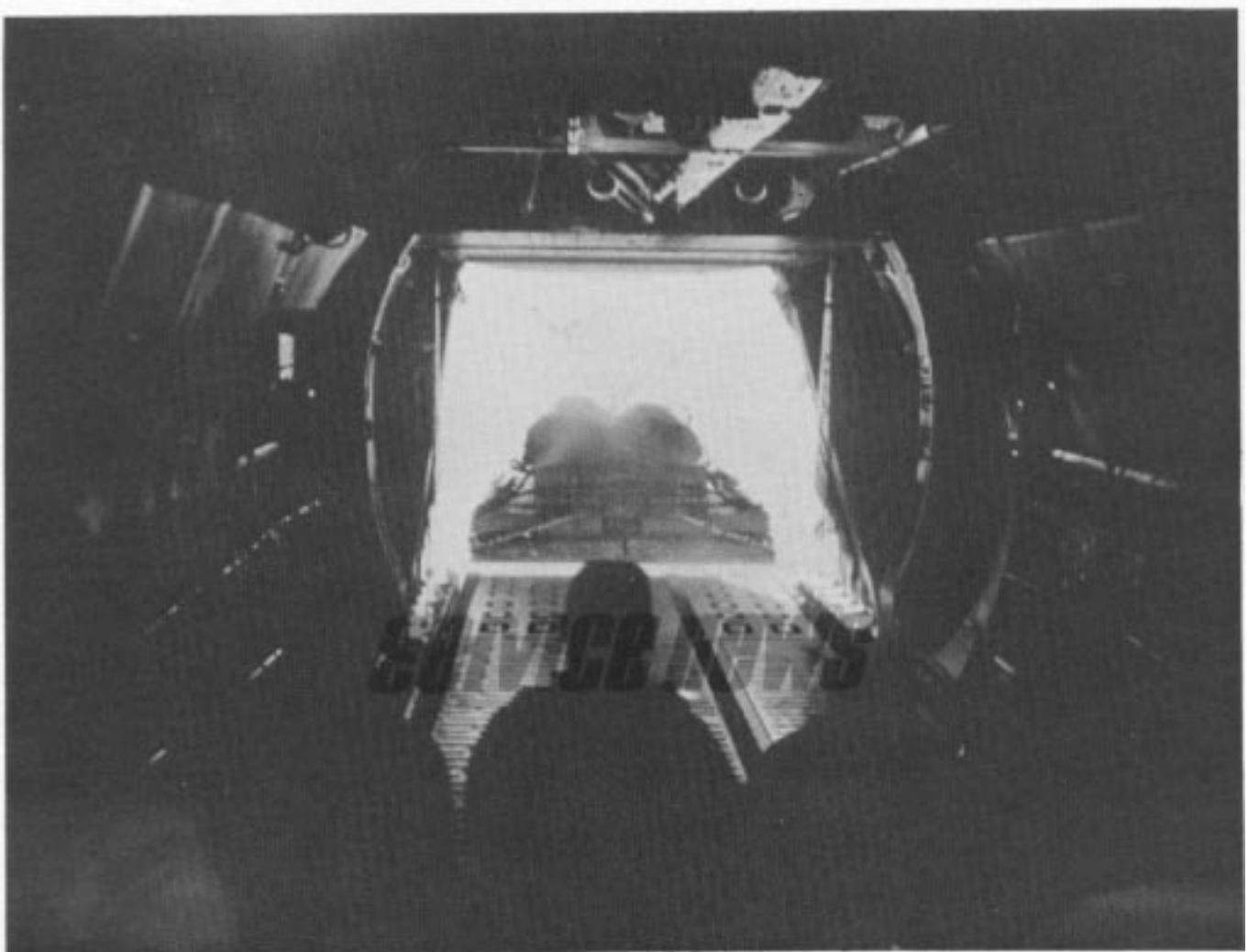

 *Lockheed-Georgia Company*

CUSTOMER SERVICE
LOCKHEED-GEORGIA COMPANY
A Division of Lockheed Corporation
Marietta, Georgia 30063

